



550 – Weiss korpus



362 – Aschgrau
U-112



568 - Kaschmir



374 - Grauer Stein
U727

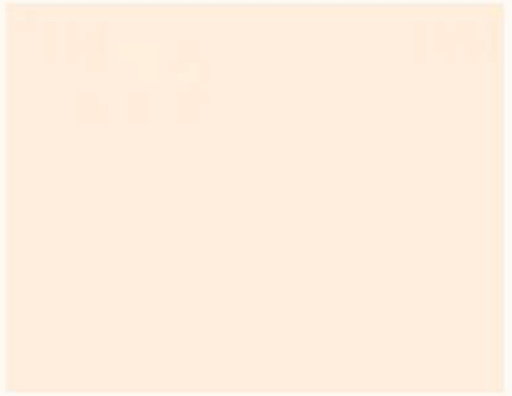

363 - crem U7035



223 – grafit
U-961



569 - Brilliantweiss



570 - kobalt grau



575 - ceramic



578 - Blau



579 - Blau



580 - Gedämpftes
Grün

Agathe

Laminierte Spanplatte mit einer Dicke von 18 mm und einer 2 mm dicken Kunststoffkante





488 -Natur-Hickorya



412 - Honigeiche
K003



393 - Dunkle Walnuss
K009

Agathe

Laminierte Spanplatte mit einer Dicke von 18 mm und einer 2 mm dicken Kunststoffkante. Horizontale Maserung. Möglichkeit der fortlaufenden Maserung.





561 - Eiche Vicenza



441 - Eiche Gold



489 - Eiche
Halifax natur



414 – Eiche natur
tabacco



468 - Eiche Gladstone
tabak



524 - Thermo-Braun
Lärche

Penelope

Laminierte Spanplatte mit einer Dicke von 18 mm und einer 1 mm dicken Kunststoffkante. Horizontale Maserung. Möglichkeit der fortlaufenden Maserung





562 - Nuss Lincoln



558 - paulownia



554 - bruciato nero

Penelope

Laminierte Spanplatte mit einer Dicke von 18 mm und einer 1 mm dicken Kunststoffkante. Horizontale Maserung. Möglichkeit der fortlaufenden Maserung





482 - torano FC13



483 - albox FC19



481 - montilla FC18



523 - chromix braun



528 - iron flow



428 - beton ares

Penelope

Laminierte Spanplatte mit einer Dicke von 18 mm und einer 1 mm dicken Kunststoffkante





571 - curio

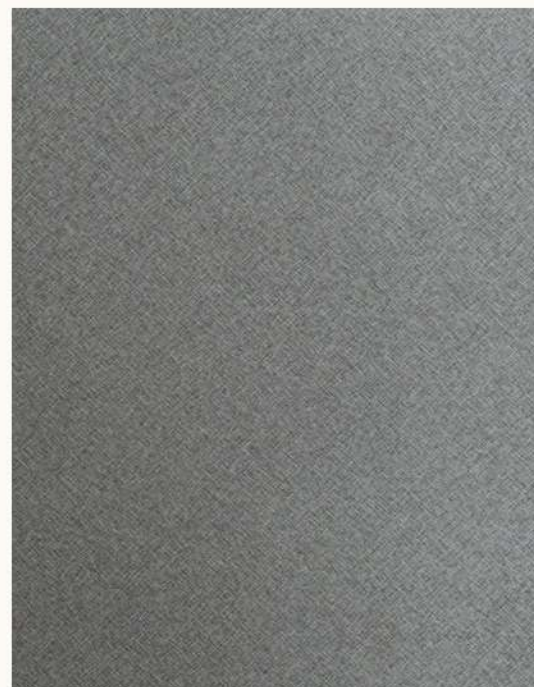

572 - tellurio

Penelope

Laminierte Spanplatte mit einer Dicke von 18 mm und einer 1 mm dicken Kunststoffkante





468 - Stein oxid

Avila

Laminierte Spanplatte mit einer Dicke von 18 mm und einer 1 mm dicken Kunststoffkante





001 - natural oak



565 – Eiche natur
flader



378 - Eiche Natur
Parkett



217 – european oak



315 - American
wallnuss

Oktavia

Spanplatte mit furnierter Beschichtung und furniertem Kantenabschluss. Horizontale Maserung. Fortsetzung der Maserung für Dekore 315 und 565. Frontdicke 18 mm

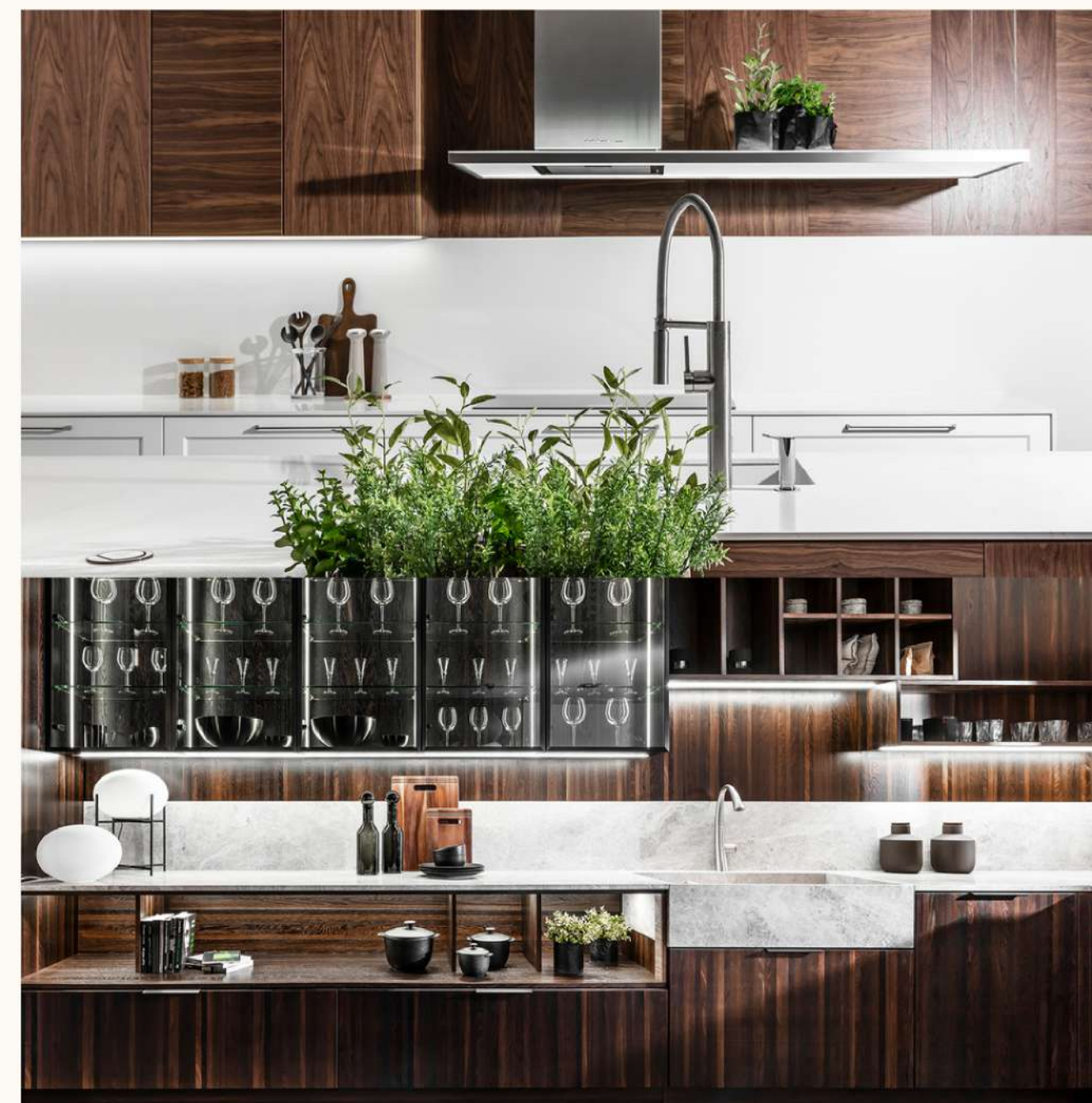



480 - Eiche hell,astig

Nodoso

MDP-Platte mit einer Eichenfurnier-Oberfläche von 2 mm - auf beiden Oberflächen und den vier Kanten, Frontstärke 20 mm, mit einer 2 mm Fase. Horizontale Maserung.

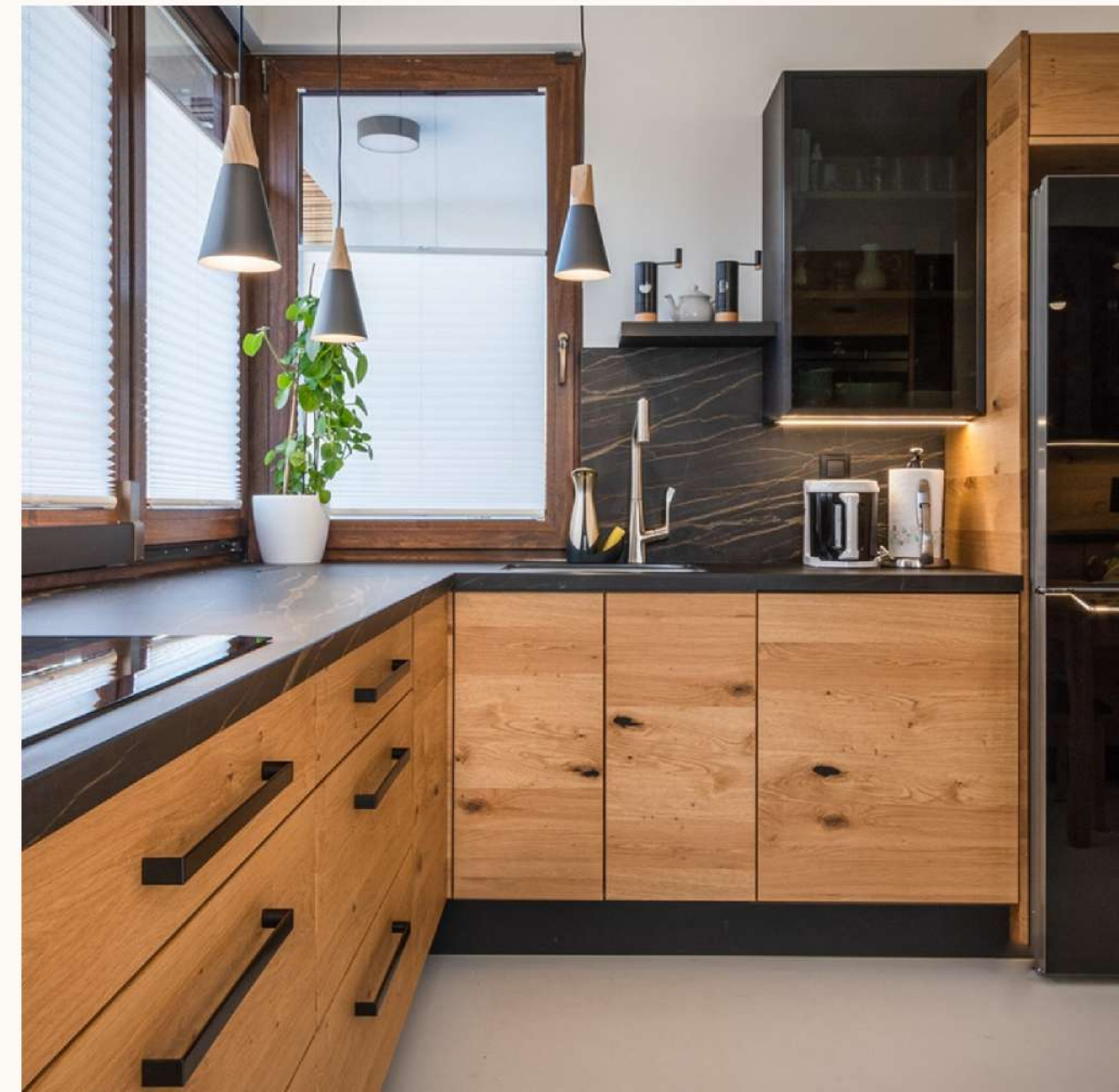



511 - Uriges Brett



529 - Uriges Brett
matt

Bordo

Front aus altem, abgebautem Holz mit einer Dicke von 20-21 mm, auf Sperrholzbasis, furniert, Holzmuster vertikal angeordnet im Used-Look-Stil für Authentizität und Imperfektionen des alten Holzes. Frontkonstruktion als Sandwich-Prinzip. Die rechte Seite des Fronts besteht aus Recycling-Weichholz (Kiefer, Fichte, Tanne) im Stil einer 'alten Diele' in Form einer dicken Furnierschicht von 6-7 mm auf einer Sperrholzbasis. Die Kante ist mit einem Furnier von 0,6-1 mm Dicke versehen. Vertikale Fortführung der Dielenbreite. Die Oberfläche der Fronten ist mit einem wasserbasierten Lack auf Polyurethan- und Acrylbasis versiegelt





512 – kawa

Spina

Front aus altem, abgebautem Holz mit einer Dicke von 20-21 mm, auf Sperrholzbasis, furniert mit einer Tannenmusterung im Modul von 150 mm, Used-Look-Stil für Authentizität und Unvollkommenheiten des alten Holzes. Frontkonstruktion als Sandwich-Prinzip. Die rechte Seite des Fronts besteht aus Recycling-Weichholz (Kiefer, Fichte, Tanne) im Stil einer 'alten Diele' in Form einer dicken Furnierschicht von 6-7 mm auf einer Sperrholzbasis. Die Kante ist mit einem Furnier von 0,6-1 mm Dicke versehen. Fortführung des Tannenmusters auf benachbarten Fronten. Die Oberfläche der Fronten ist mit einem wasserbasierten Lack auf Polyurethan- und Acrylbasis versiegelt

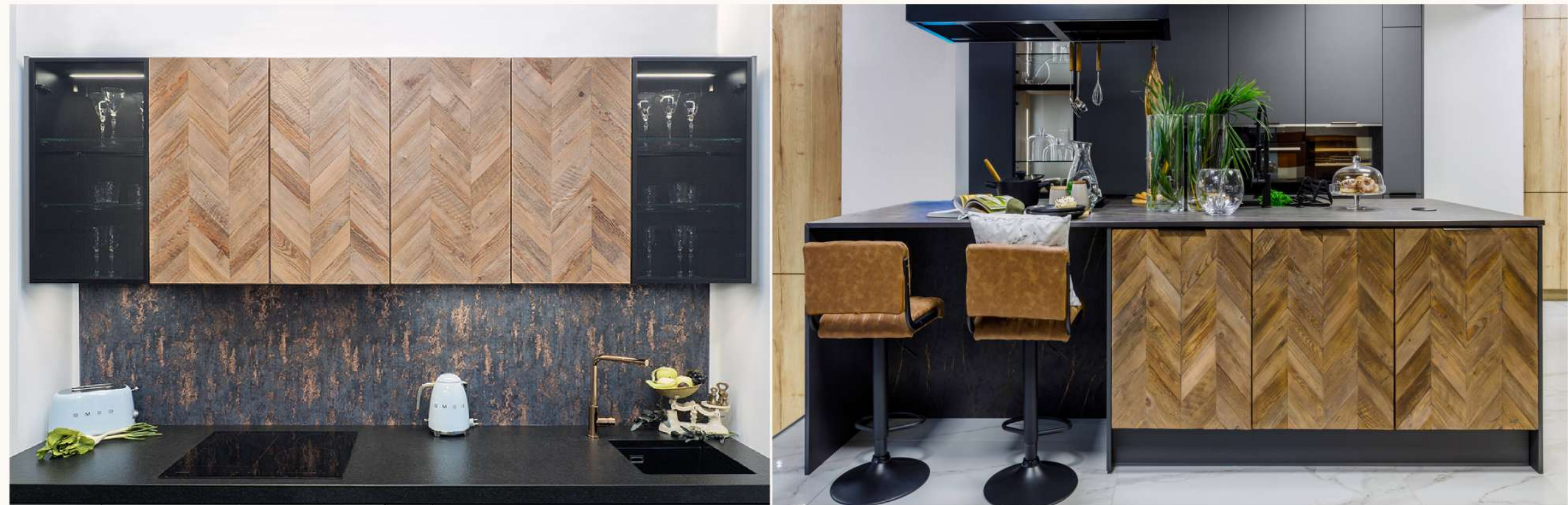



462 - Weiss matt



464 - Kaschmir matt



466 - Dunkelgrau matt



467 - Schwarz matt



463 - vanille matt

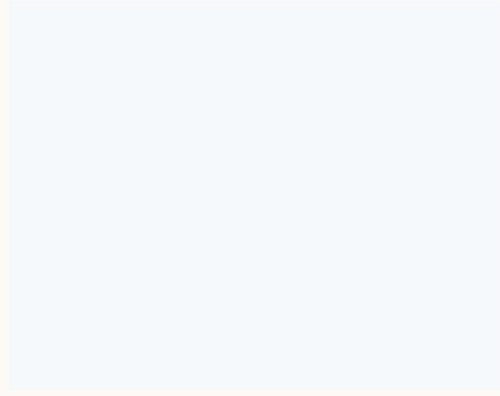

415 - Weiss glänzend



416 - kaschmir glänzend

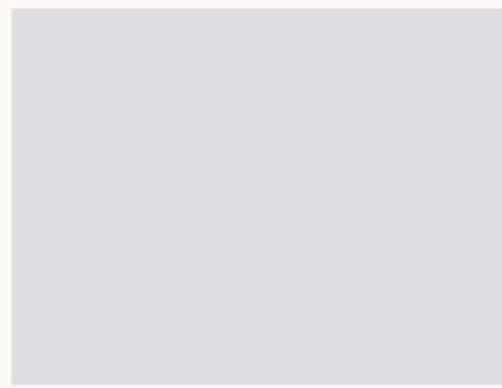

417 - Grau Glänzend



421 - cappuccino

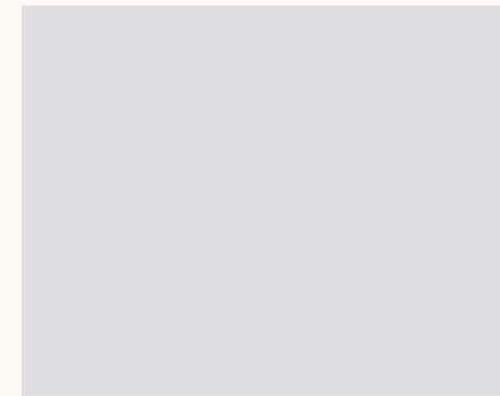

417 - Grau

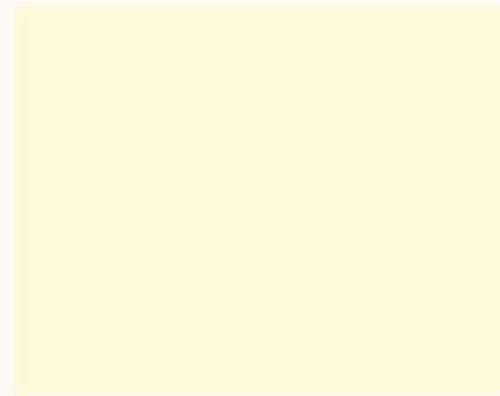

422 - vanille glänzend



420 - Schwarz glänzend

Olivia

19 mm dicke MDF-Platte mit Acrylux-Folie in glänzend oder matt, mit einem 1 mm dicken Acrylux-Kantenabschluss. Die Oberfläche ist entweder seidenglänzend (4 gloss) oder matt, nicht brennbar. Die linke Seite des Fronts hat eine matte Oberfläche mit einer perlenartigen Struktur, die dem Frontfarbton ähnlich ist



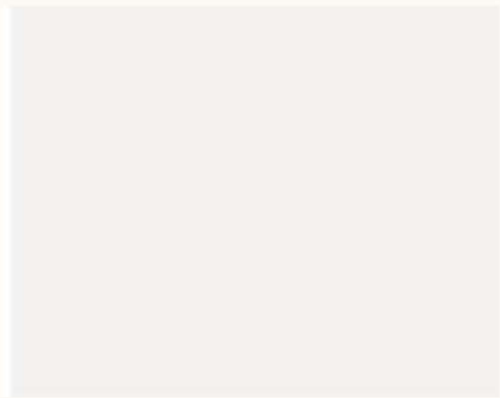

542 -
Porzellanweiss



543 - Grau

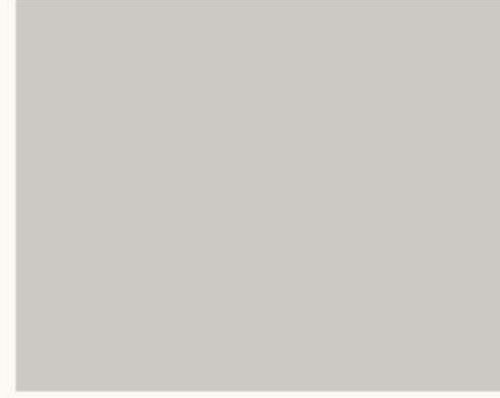

581 - Hellgrau



582 - Aschgrau

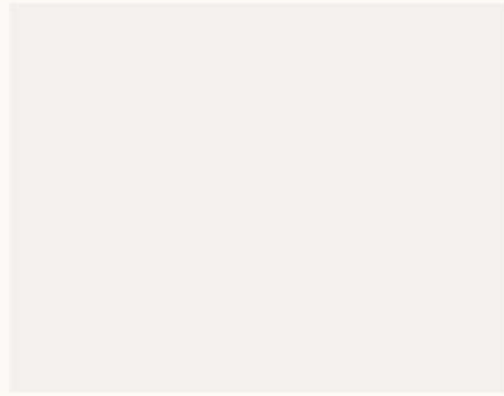

585 - Alpinweiß



583 - Dunkles
Beige



584 - Hellbeige

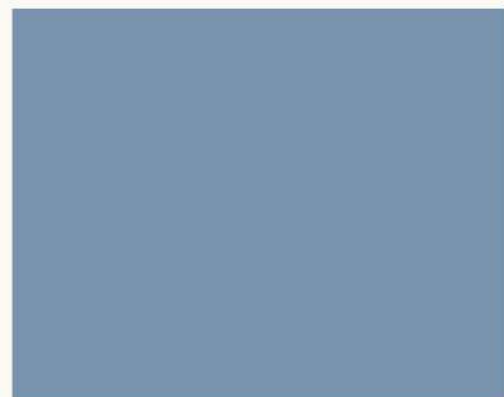

544 - Blau



545 - Dunkelblau



563 - Dunkelgrün

Velluto

19 mm dicke MDF-Platte mit einer PVC-Folie, geschützt durch einen klaren Supermat-Lack mit 3 glossy-Eigenschaften, nicht brennbar. Die linke Seite des Fronts entspricht dem Material und der Farbe der rechten Seite. Die ABS-Kante ist 1 mm dick und hat dieselbe Farbe wie die Front.





470 - total white
HM00



4472 - visione
HM04



508 - canapa Hanf
HM02



467 - Mattschwarz
HM02



557 - London Grey
HM08



473 - grigio HM06



509 - grigio HM05

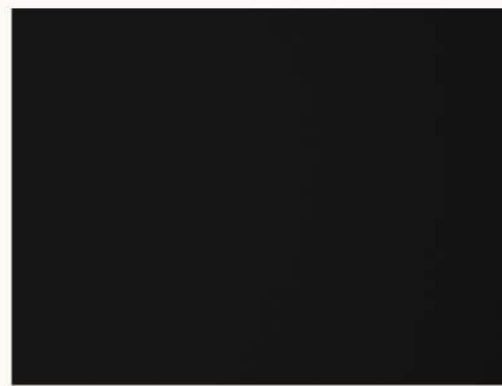

474 - nero HM07

Piombo

19 mm dicke MDF-Platte, beschichtet mit mattem Acrylharz, linke Seite der Front mit glattem Laminat in der Farbe der rechten Seite, ABS-Kante mit einer Dicke von 1 mm in der Frontfarbe. Finish mit Supermat 3 Gloss.



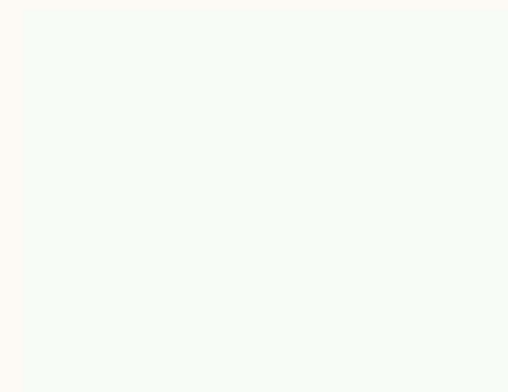

020 – Weiß matt



148 - Grau matt

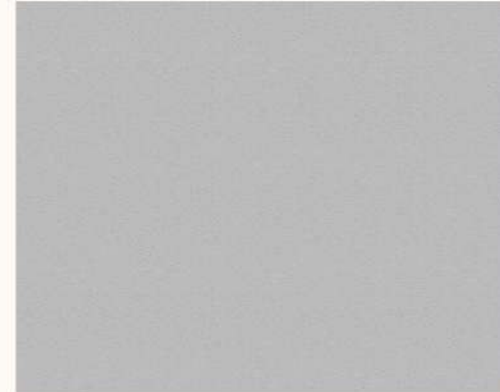

450 - Mattes Beige



525 - Platingrau
Matt



349 - Antikes Weiß
Matt



534 - Basisgrau
Matt



182 - Mattes
Graphit

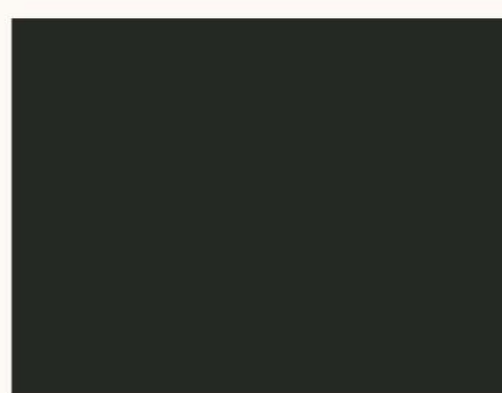

442 - Anthrazit
Matt



071 - Cremeweiß
Matt



559 - Mattes Latte



444 – kaschmir
matt

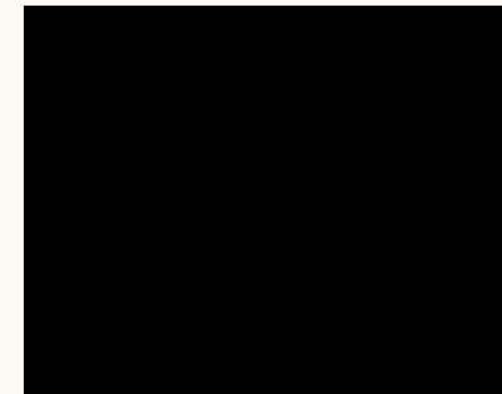

166 - Schwarz matt

Oktavia

19 mm dicke MDF-Platte, lackiert mit einer flachen Oberfläche, 3 mm Radius an den Kanten, Finish mit Supermat (3 Glanzgrade), Matt (8-12 Glanzgrade) oder Hochglanz (>95 Glanzgrade). Die linke Seite ist lackiert in der Farbe der rechten Seite, immer mit einem matten Finish.





384 -Steingrau
matt

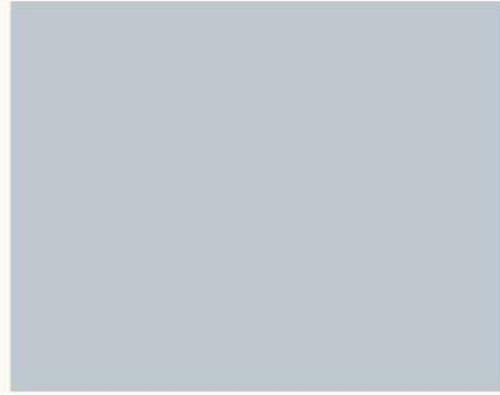

531 - Graublau
matt



530 - Zartes Rosa
Matt



311 - Magnolie
Matt



574 - Olivgrün Matt



446-Smaragdgrün
matt



000 - Jede RAL /
NCS Farbe

Oktavia

19 mm dicke MDF-Platte, lackiert mit einer flachen Oberfläche, 3 mm Radius an den Kanten, Finish mit Supermat (3 Glanzgrade), Matt (8-12 Glanzgrade) oder Hochglanz (>95 Glanzgrade). Die linke Seite ist lackiert in der Farbe der rechten Seite, immer mit einem matten Finish.



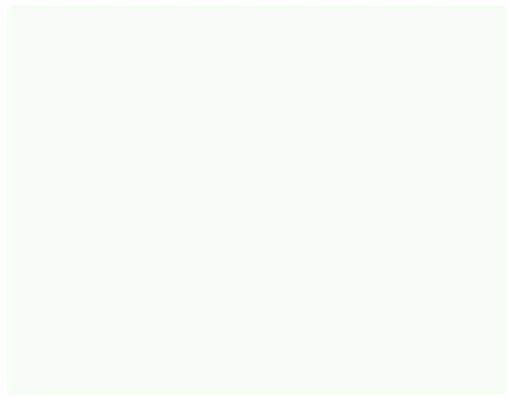

159 - Weiß Glänzend



312 - Magnolie Glänzend

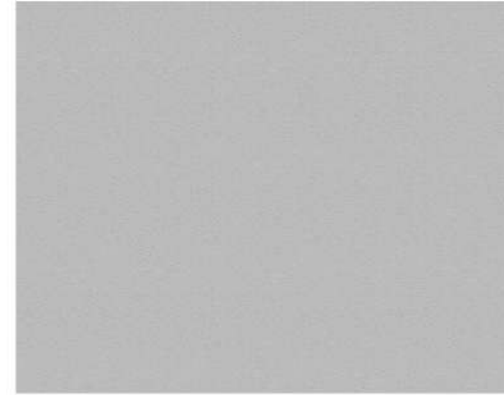

451 - Beige Glänzend



000 - Jede RAL / NCS Farbe



158 - bianco creme Glänzend



533 - Latte Glänzend



445 - Kaschmir Glänzend



385 - Steingrau Glänzend

Oktavia

19 mm dicke MDF-Platte, lackiert mit einer flachen Oberfläche, 3 mm Radius an den Kanten, Finish mit Supermat (3 Glanzgrade), Matt (8-12 Glanzgrade) oder Hochglanz (>95 Glanzgrade). Die linke Seite ist lackiert in der Farbe der rechten Seite, immer mit einem matten Finish.



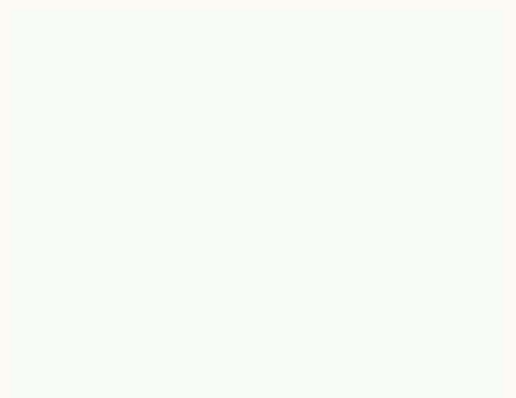

535 - Weiß
Superma



541 - Kaschmir
Supermat

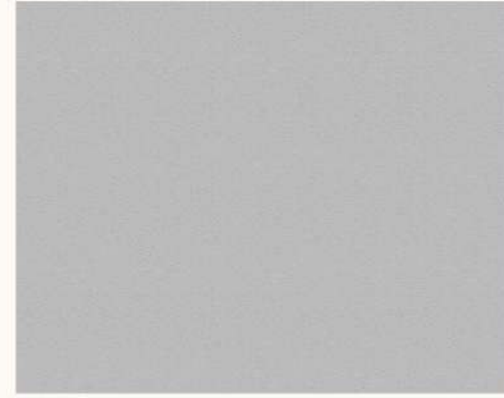

536 - Beige
Supermat



537 - Platingrau
Supermat



538 - Graphit
Supermat

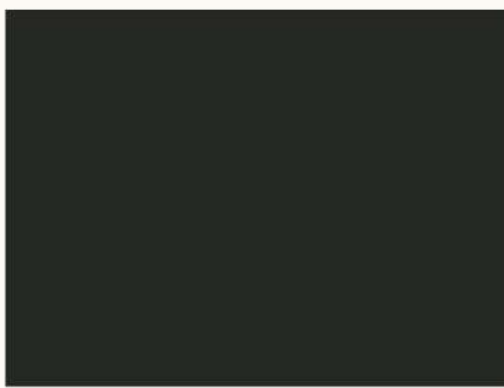

539 - Anthrazit
Supermat

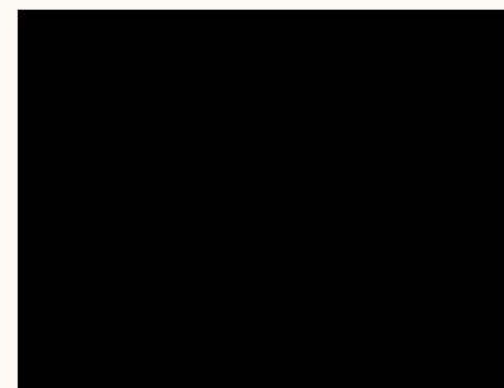

540 - Schwarz
Supermat



000 - Jede RAL /
NCS Farbe

Oktavia

19 mm dicke MDF-Platte, lackiert mit einer flachen Oberfläche, 3 mm Radius an den Kanten, Finish mit Supermat (3 Glanzgrade), Matt (8-12 Glanzgrade) oder Hochglanz (>95 Glanzgrade). Die linke Seite ist lackiert in der Farbe der rechten Seite, immer mit einem matten Finish.



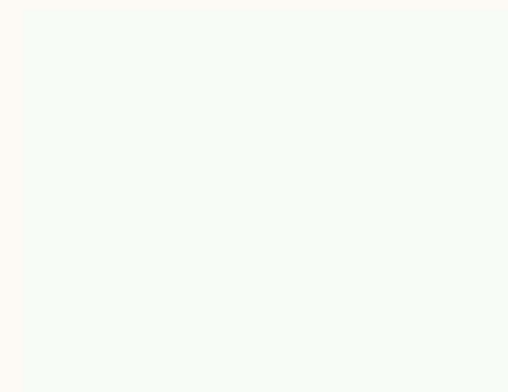

020 – Weiß matt



148 - Grau matt

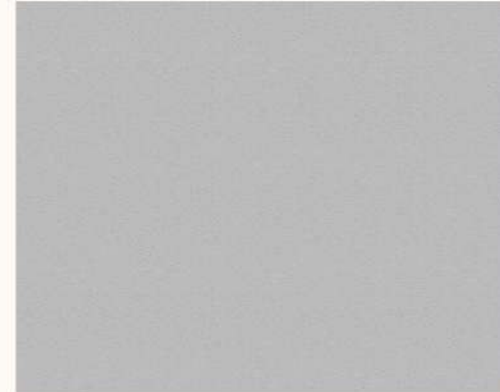

450 – Beige matt



525 - Platingrau
Matt



349 - Antikes Weiß
Matt



534 - Basisgrau
Matt



182 – Graphit matt

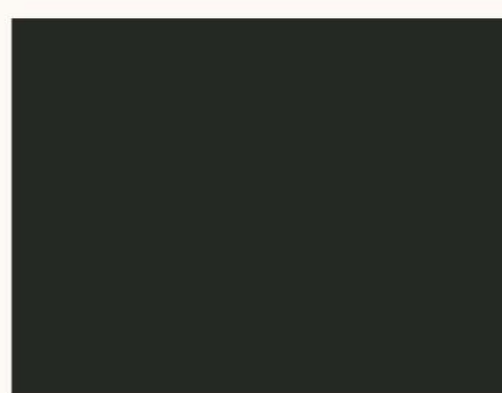

442 - Anthrazit
Matt



071 - bianco creme
matt



559 - latte matt



444 - Kaschmir
Matt

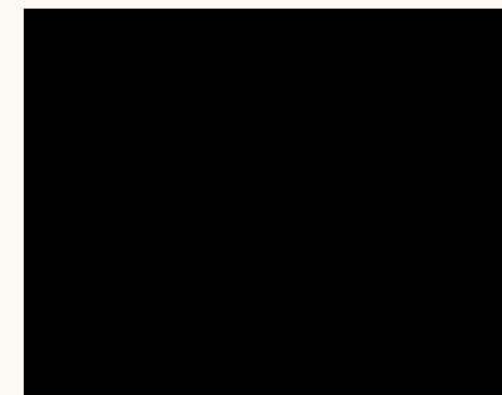

166 - Schwarz matt

Patricia

19 mm dicke MDF-Platte, lackiert mit einer flachen Oberfläche, 3 mm Radius an den Kanten, Finish mit Supermat (3 Glanzgrade), Matt (8-12 Glanzgrade) oder Hochglanz (>95 Glanzgrade). Die linke Seite ist lackiert in der Farbe der rechten Seite, immer mit einem matten Finish.





384 - Steingrau
Matt

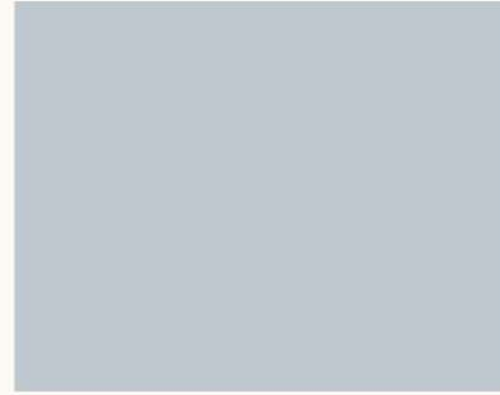

531 - Graublau
Matt



530 - Zartes Rosa
Matt



311 - Magnolie
Matt



574 - Olivgrün Matt



446 - Smaragdgrün
Matt



000 - Jede RAL /
NCS Farbe

Patricia

19 mm dicke MDF-Platte, lackiert mit einer flachen Oberfläche, 3 mm Radius an den Kanten, Aussparung anstelle eines Griffs an einer horizontalen Kante, Finish mit Supermat (3 Glanzgrade), Matt (8-12 Glanzgrade) oder Hochglanz (>95 Glanzgrade). Die linke Seite ist lackiert in der Farbe der rechten Seite, immer mit einem matten Finish



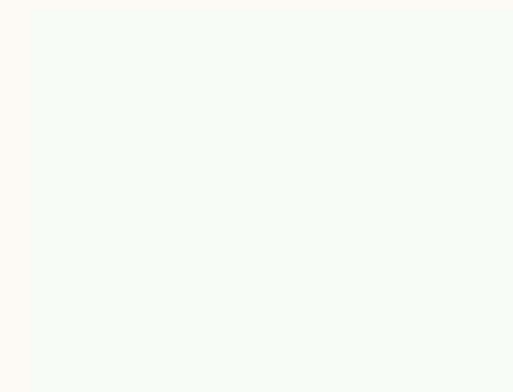

159 - Weiß
Glänzend



312 - Magnolie
Glänzend

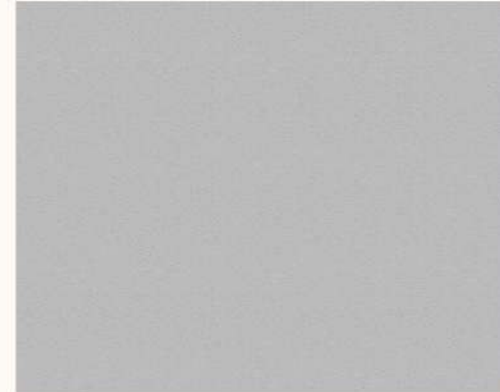

158 - Cremeweiß
Glänzend



000 - Jede RAL /
NCS Farbe



158 - Cremeweiß
Glänzend



533 - Latte
Glänzend



445 - Kaschmir
Glänzend



385 - Steingrau
Glänzend

Patricia

19 mm dicke MDF-Platte, lackiert mit einer flachen Oberfläche, 3 mm Radius an den Kanten, Aussparung anstelle eines Griffs an einer horizontalen Kante, Finish mit Supermat (3 Glanzgrade), Matt (8-12 Glanzgrade) oder Hochglanz (>95 Glanzgrade). Die linke Seite ist lackiert in der Farbe der rechten Seite, immer mit einem matten Finish





5535 - Weiß
Supermat



541 - Kaschmir
Supermat

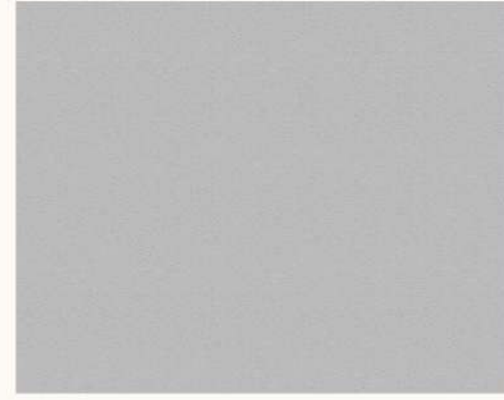

536 - Beige
Supermat



537 - Platingrau
Supermat



538 - Graphit
Supermat



539 - Anthrazit
Supermat

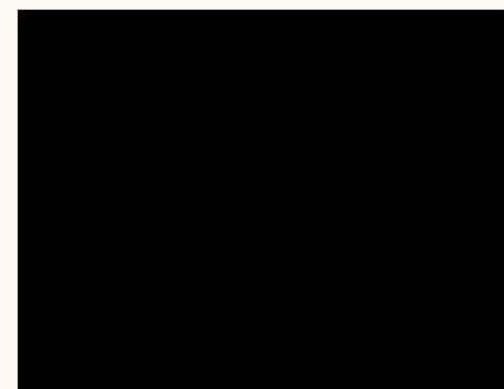

540 - Schwarz
Supermat



000 - Jede RAL /
NCS Farbe

Patricia

19 mm dicke MDF-Platte, lackiert mit einer flachen Oberfläche, 3 mm Radius an den Kanten, Aussparung anstelle eines Griffs an einer horizontalen Kante, Finish mit Supermat (3 Glanzgrade), Matt (8-12 Glanzgrade) oder Hochglanz (>95 Glanzgrade). Die linke Seite ist lackiert in der Farbe der rechten Seite, immer mit einem matten Finish



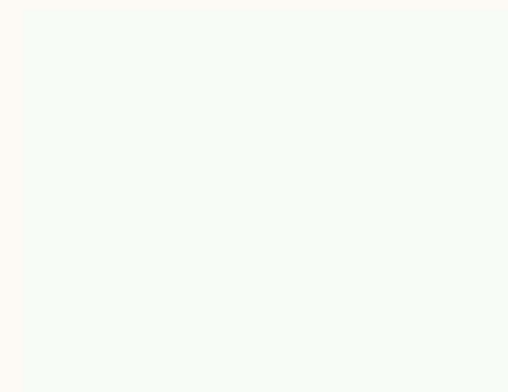

Weiß Matt - 020



Grau Matt - 148

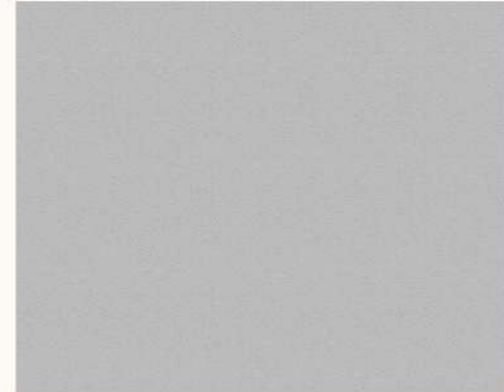

Beige Matt - 450



Platingrau Matt - 525



Antikes Weiß Matt - 349



Basisgrau Matt - 534



Graphit Matt - 182

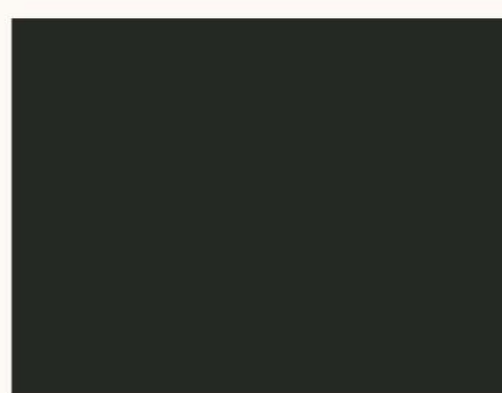

4Anthrazit Matt - 442



Cremeweiß Matt - 071



Latte Matt - 559



Kaschmir Matt - 444

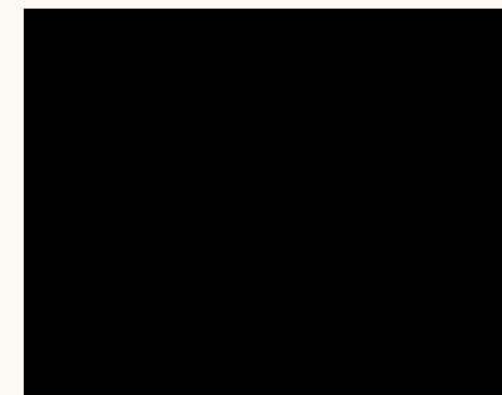

Schwarz Matt - 166

Scanalato

19 mm dicke MDF-Platte, lackiert mit vertikalen Rillen mit einem Abstand von 7 mm und einem Radius von 3 mm an den Kanten. Finish mit Supermat (3 Glanzgrade) oder Matt (8-12 Glanzgrade). Die linke Seite ist in der Farbe der rechten Seite lackiert und immer matt





384 - Steingrau
Matt

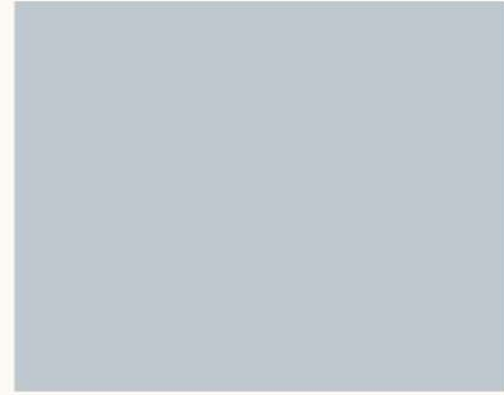

531 - Graublau
Matt



530 - Zartes Rosa
Matt



311 - Magnolie
Matt



574 - oliwkowy mat



446 - Smaragdgrün
Matt



000 - Jede RAL /
NCS Farbe

Scanalato

19 mm dicke MDF-Platte, lackiert mit vertikalen Rillen mit einem Abstand von 7 mm und einem Radius von 3 mm an den Kanten. Finish mit Supermat (3 Glanzgrade) oder Matt (8-12 Glanzgrade). Die linke Seite ist in der Farbe der rechten Seite lackiert und immer matt





535 - Weiß
Supermat



541 - Kaschmir
Supermat

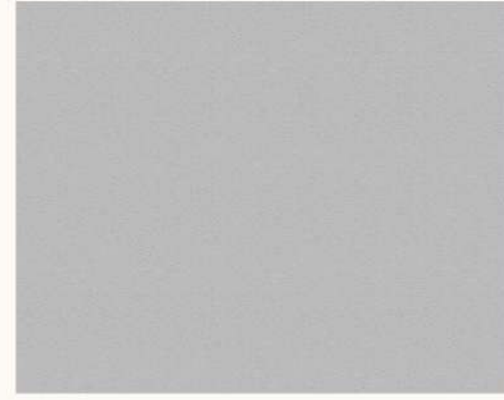

536 - Beige
Supermat



537 - Platingrau
Supermat



538 - Graphit
Supermat

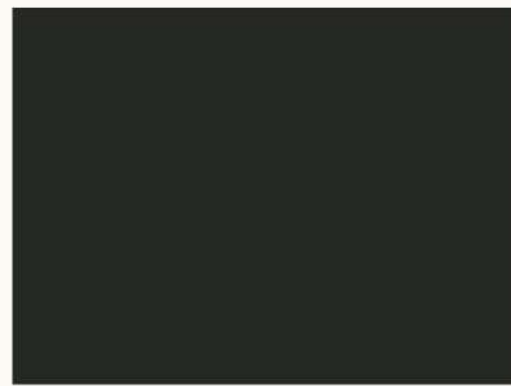

539 - Anthrazit
Supermat

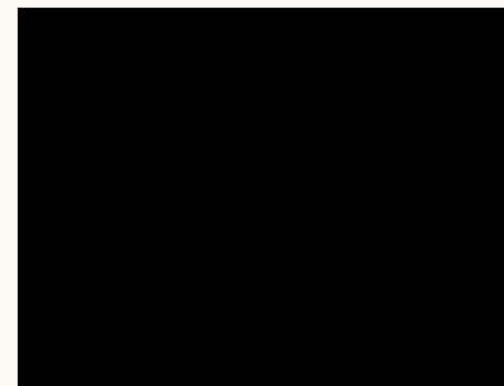

540 - Schwarz
Supermat



000 - Jede RAL /
NCS Farbe

Scanalato

19 mm dicke MDF-Platte, lackiert mit vertikalen Rillen mit einem Abstand von 7 mm und einem Radius von 3 mm an den Kanten. Finish mit Supermat (3 Glanzgrade) oder Matt (8-12 Glanzgrade). Die linke Seite ist in der Farbe der rechten Seite lackiert und immer matt



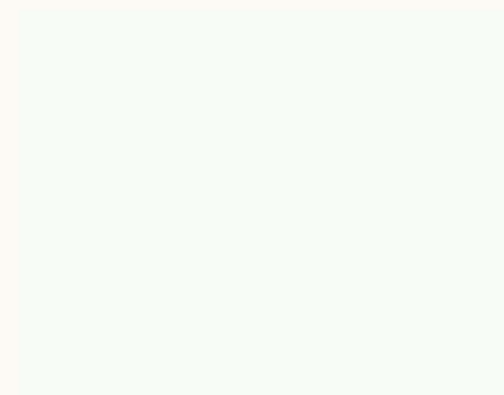

Weiß Matt - 020



Grau Matt - 148

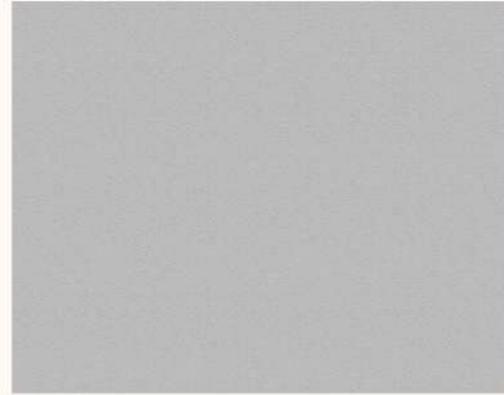

Beige Matt - 450



Platingrau Matt -
525

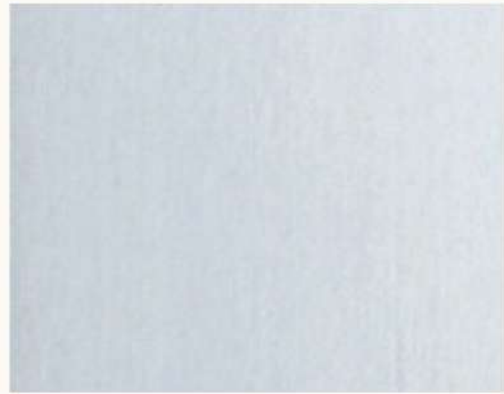

Antikes Weiß Matt -
349



Basisgrau Matt -
534



Graphit Matt - 182

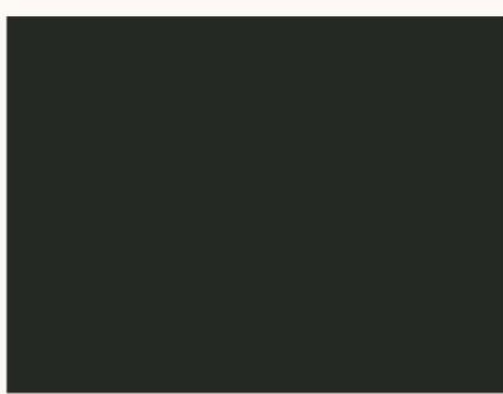

Anthrazit Matt -
442



Cremeweiß Matt -
071



Latte Matt - 559



Kaschmir Matt -
444

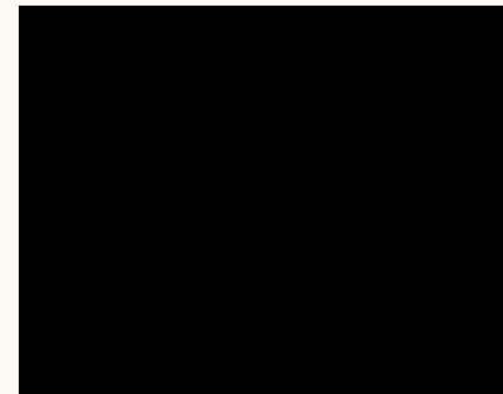

Schwarz Matt - 166

Semplice

22 mm dicke MDF-Platte, lackiert mit einem Rahmen von 8 mm Breite. Finish mit Supermat (3 Glanzgrade) oder Matt (8-12 Glanzgrade). Die linke Seite ist in der Farbe der rechten Seite lackiert und immer mattiert





384 - Steingrau
Matt

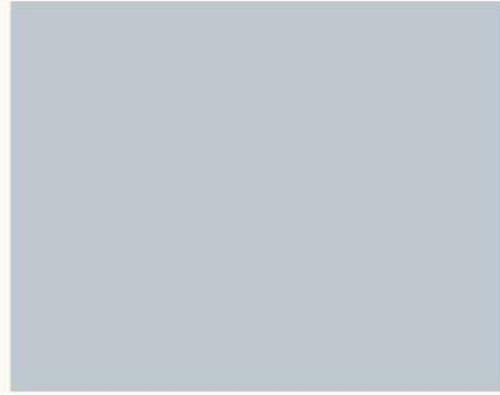

531 - Graublau
Matt



530 - Zartes Rosa
Matt



311 - Magnolie
Matt



574 - Olivgrün Matt



446 - Smaragdgrün
Matt



000 - Jede RAL /
NCS Farbe

Semplice

22 mm dicke MDF-Platte, lackiert mit einem Rahmen von 8 mm Breite. Finish mit Supermat (3 Glanzgrade) oder Matt (8-12 Glanzgrade). Die linke Seite ist in der Farbe der rechten Seite lackiert und immer mattiert





535 - Weiß
Supermat



541 - Kaschmir
Supermat

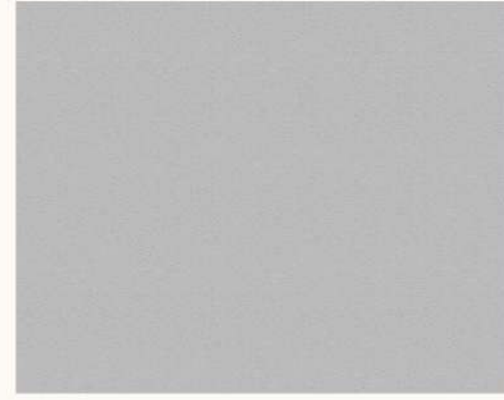

536 - Beige
Supermat



537 - Platingrau
Supermat



538 - Graphit
Supermat

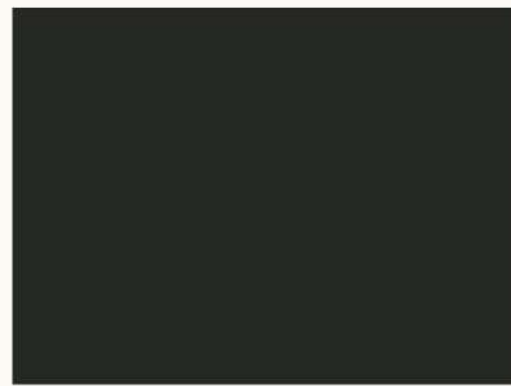

539 - Anthrazit
Supermat

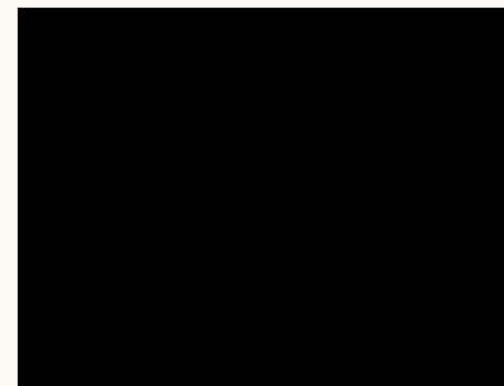

540 - Schwarz
Supermat



000 - Jede RAL /
NCS Farbe

Semplice

22 mm dicke MDF-Platte, lackiert mit einem Rahmen von 8 mm Breite. Finish mit Supermat (3 Glanzgrade) oder Matt (8-12 Glanzgrade). Die linke Seite ist in der Farbe der rechten Seite lackiert und immer mattiert



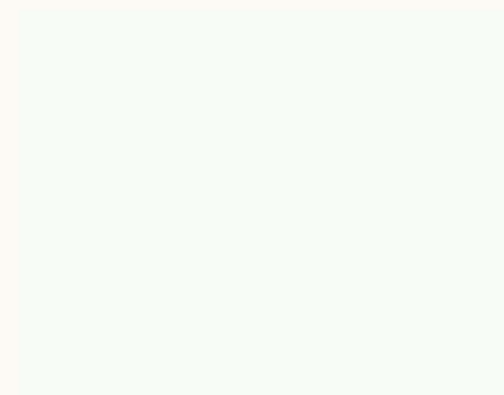

Weiß Matt - 020



Grau Matt - 148

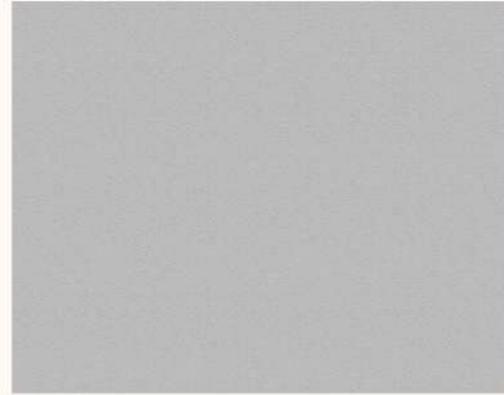

Beige Matt - 450



Platingrau Matt -
525



Antikes Weiß Matt -
349



Basisgrau Matt -
534



Graphit Matt - 182

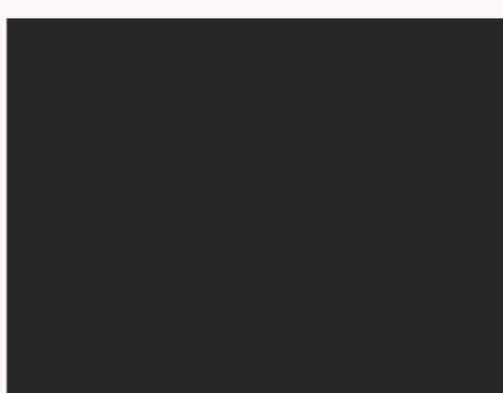

Anthrazit Matt -
442



Cremeweiß Matt -
071



Latte Matt - 559



Kaschmir Matt -
444

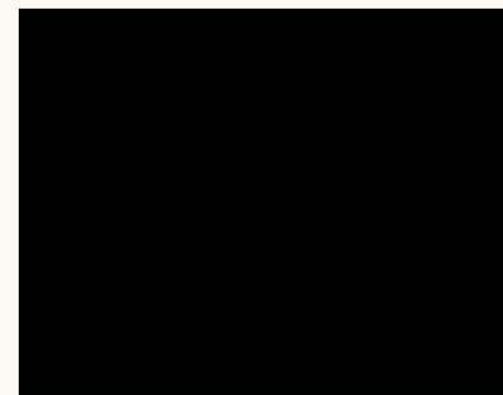

Schwarz Matt - 166

Delicata

19 mm dicke MDF-Platte, lackiert mit einem dezenten Rahmenmuster, Finish mit Supermat (3 Glanzgrade) oder Matt (8-12 Glanzgrade). Die linke Seite ist in der Farbe der rechten Seite lackiert und immer mattiert





384 - Steingrau
Matt

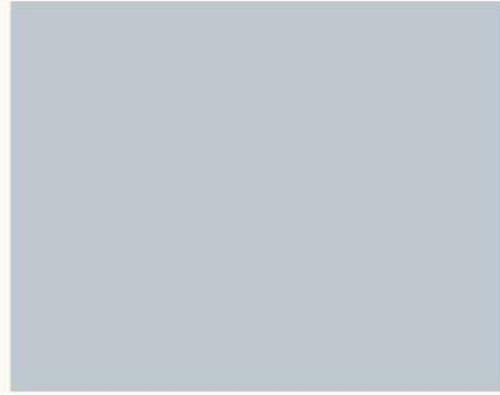

531 - Graublau
Matt



530 - Zartes Rosa
Matt



311 - Magnolie
Matt



574 - Olivgrün Matt



446 - Smaragdgrün
Matt



00 - Jede RAL /
NCS Farbe

Delicata

19 mm dicke MDF-Platte, lackiert mit einem dezenten Rahmenmuster, Finish mit Supermat (3 Glanzgrade) oder Matt (8-12 Glanzgrade). Die linke Seite ist in der Farbe der rechten Seite lackiert und immer mattiert.





535 - Weiß
Supermat



541 - Kaschmir
Supermat

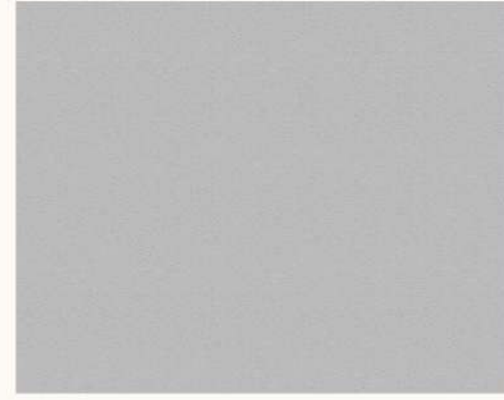

536 - Beige
Supermat



537 - Platingrau
Supermat



538 - Graphit
Supermat

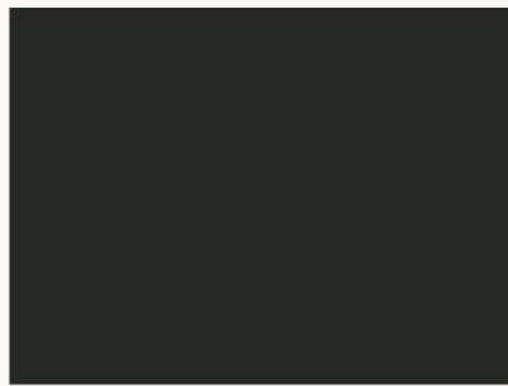

539 - Anthrazit
Supermat

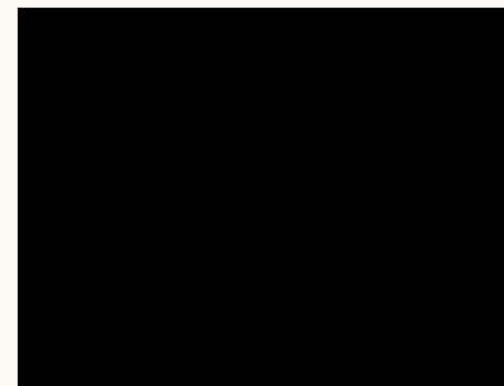

540 - Schwarz
Supermat



000 - Jede RAL /
NCS Farbe

Delicata

19 mm dicke MDF-Platte, lackiert mit einem dezenten Rahmenmuster, Finish mit Supermat (3 Glanzgrade) oder Matt (8-12 Glanzgrade). Die linke Seite ist in der Farbe der rechten Seite lackiert und immer mattiert.





Weiß Matt - 020



148 - Mattes Grau

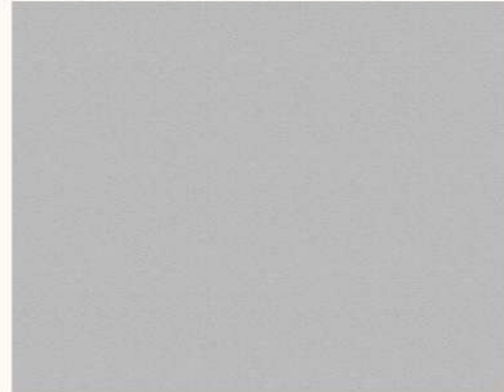

Beige Matt - 450



Platingrau Matt -
525



Antikes Weiß Matt -
349



Basisgrau Matt -
534



Graphit Matt - 182

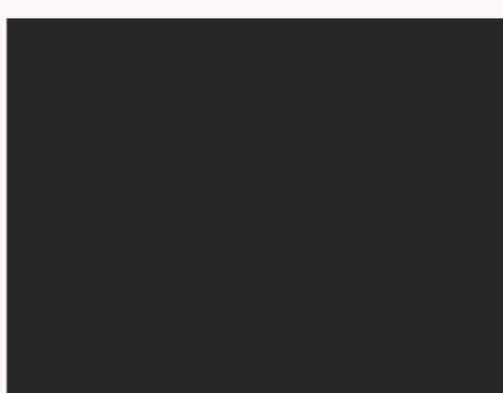

4Anthrazit Matt -
442



Cremeweiß Matt -
071



Latte Matt - 559



Kaschmir Matt -
444

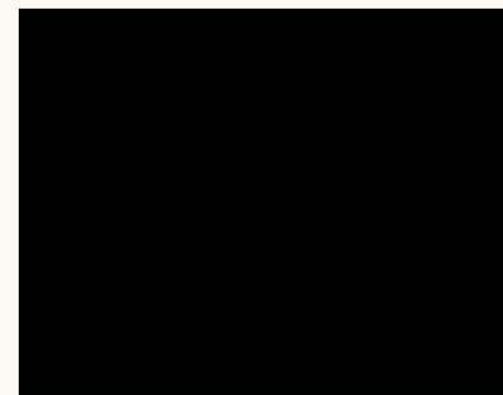

Schwarz Matt - 166

Durevole

19 mm MDF-Platte, lackiert mit einem Rahmenmuster, Finish mit Supermat (3 Glossy) oder Matt (8-12 Glossy). Die linke Seite ist in der Farbe der rechten Seite lackiert und immer in mattem Finish





384 - Steingrau
Matt

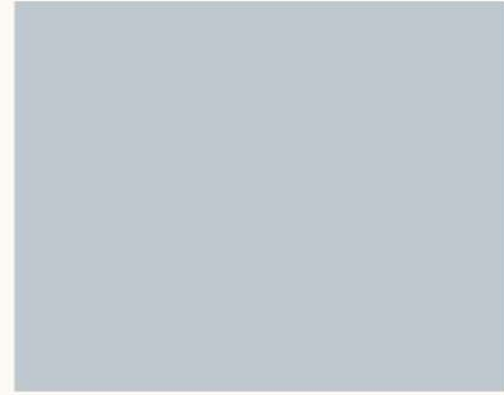

531 - Graublau
Matt



530 - Zartes Rosa
Matt



311 - Magnolie
Matt



574 - Olivgrün Matt



446 - Smaragdgrün
Matt



000 - Jede RAL /
NCS Farbe

Durevole

19 mm MDF-Platte, lackiert mit einem Rahmenmuster, Finish mit Supermat (3 Glossy) oder Matt (8-12 Glossy). Die linke Seite ist in der Farbe der rechten Seite lackiert und immer in mattem Finish





535 - Weiß
Supermat



541 - Kaschmir
Supermat

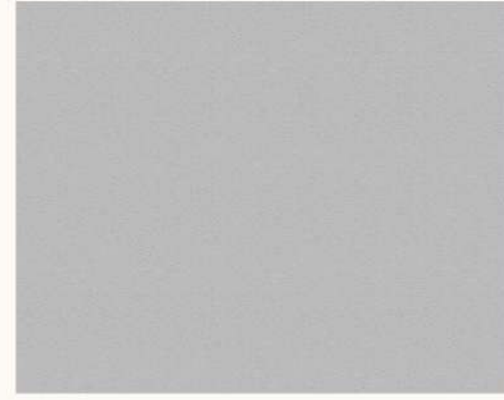

536 - Beige
Supermat



537 - Platingrau
Supermat



538 - Graphit
Supermat

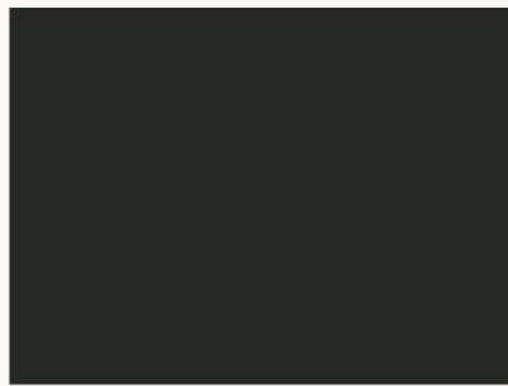

539 - Anthrazit
Supermat

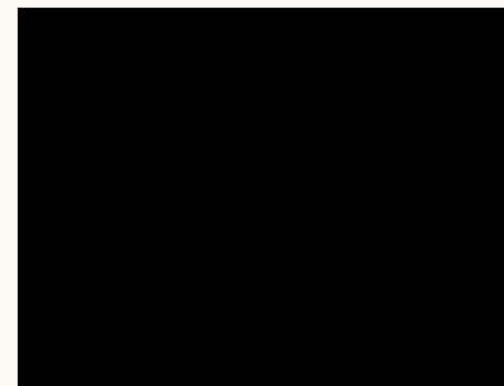

540 - Schwarz
Supermat



000 - Jede RAL /
NCS Farbe

Durevole

19 mm MDF-Platte, lackiert mit einem Rahmenmuster, Finish mit Supermat (3 Glossy) oder Matt (8-12 Glossy). Die linke Seite ist in der Farbe der rechten Seite lackiert und immer in mattem Finish



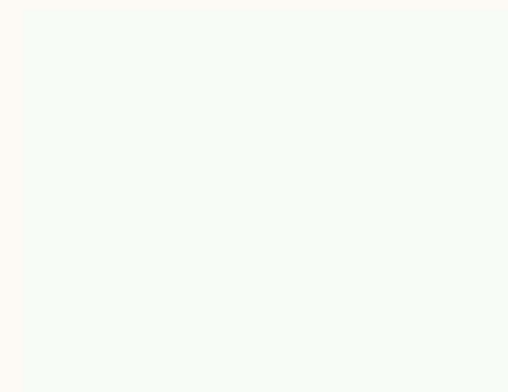

Weiß Matt - 020



Grau Matt - 148



Beige Matt - 450



Platingrau Matt -
525



Antikes Weiß Matt -
349



Basisgrau Matt -
534



Graphit Matt - 182

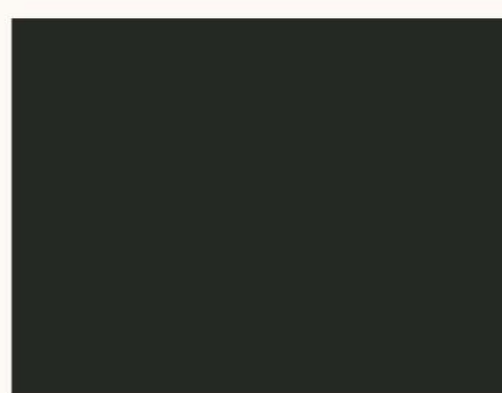

Anthrazit Matt -
442



Cremeweiß Matt -
071



Latte Matt - 559



Kaschmir Matt -
444

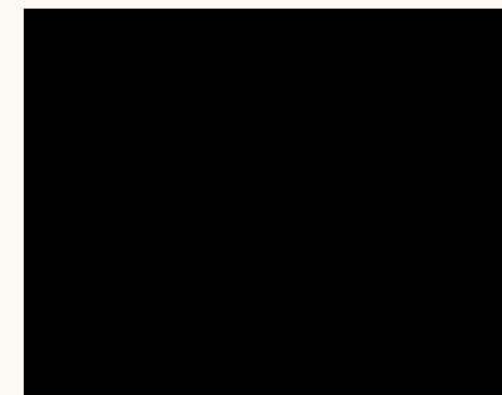

Schwarz Matt - 166

Adrienne

19 mm MDF-Platte, lackiert mit einem Rahmenmuster, Nut an der Kante des Panels, Finish mit Supermat (3 Glossy) oder Matt (8-12 Glossy). Die linke Seite ist in der Farbe der rechten Seite lackiert und immer mattiert.



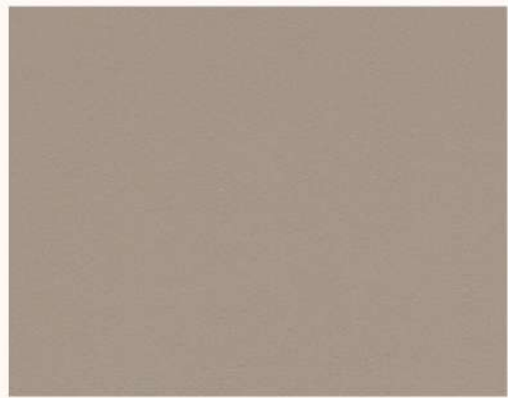

384 - Steingrau
Matt

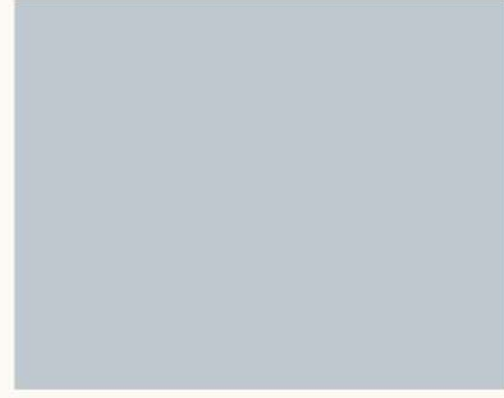

531 - Graublau
Matt



530 - Zartes Rosa
Matt



311 - Magnolie
Matt



574 - Olivgrün Matt



446 - Smaragdgrün
Matt



000 - Jede RAL /
NCS Farbe

Adrienne

19 mm MDF-Platte, lackiert mit einem Rahmenmuster, Nut an der Kante des Panels, Finish mit Supermat (3 Glossy) oder Matt (8-12 Glossy). Die linke Seite ist in der Farbe der rechten Seite lackiert und immer mattiert.





5535 - Weiß
Supermat



541 - Kaschmir
Supermat

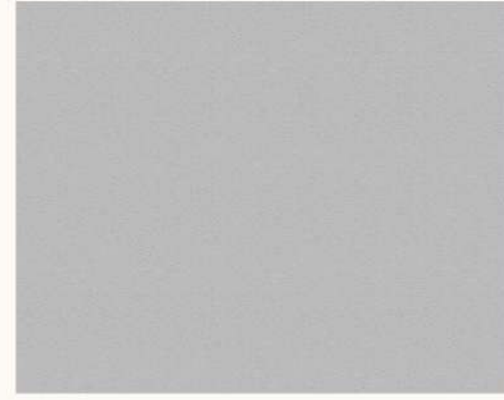

536 - Beige
Supermat



537 - Platingrau
Superma



538 - Graphit
Supermat



539 - Anthrazit
Supermat

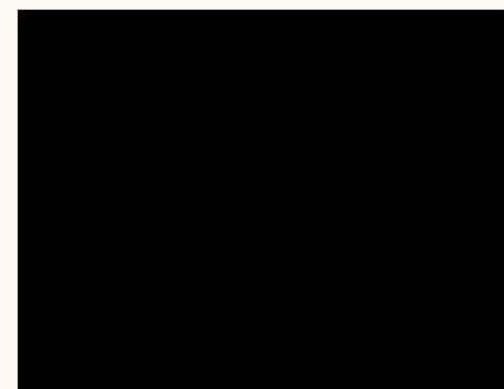

540 - Schwarz
Supermat



000 - Jede RAL /
NCS Farbe

Adrienne

19 mm MDF-Platte, lackiert mit einem Rahmenmuster, Nut an der Kante des Panels, Finish mit Supermat (3 Glossy) oder Matt (8-12 Glossy). Die linke Seite ist in der Farbe der rechten Seite lackiert und immer mattiert.



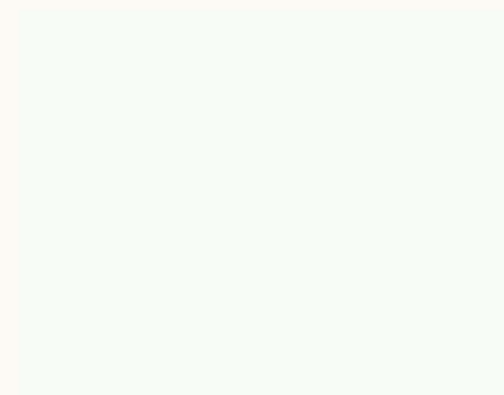

Weiß Matt - 020



Grau Matt - 148

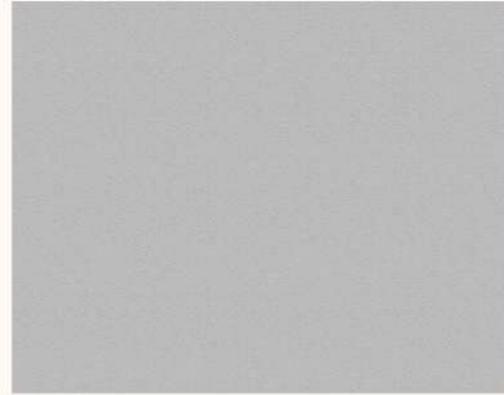

Beige Matt - 450



Platingrau Matt -
525



Antikes Weiß Matt -
349



Basisgrau Matt -
534



Graphit Matt - 182

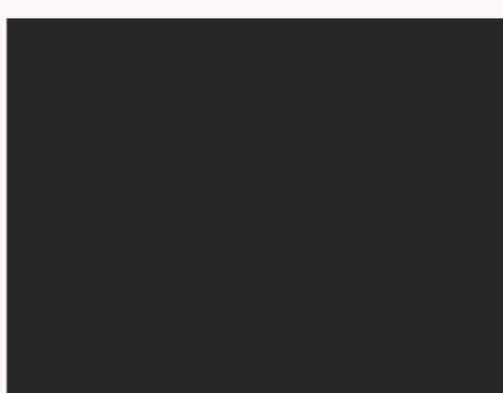

442 - antracyt
mat



Cremeweiß Matt -
071



Latte Matt - 559



Kaschmir Matt -
444

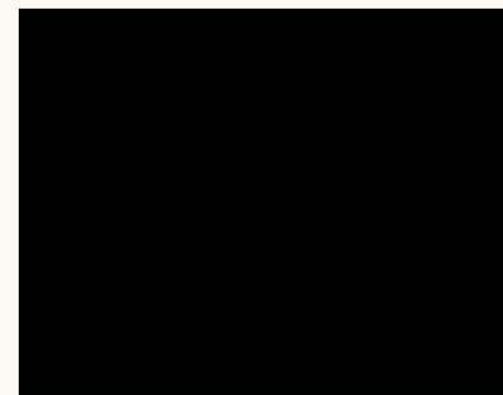

Schwarz Matt - 166

Julia

19 mm lackierte MDF-Platte mit einem Rahmenmuster, erhältlich in Supermat-Finish (3 Glanzgrad) oder Matt-Finish (8-12 Glanzgrad). Die linke Seite ist lackiert in der Farbe der rechten Seite, immer mit mattem Finish."





384 - Steingrau
Matt

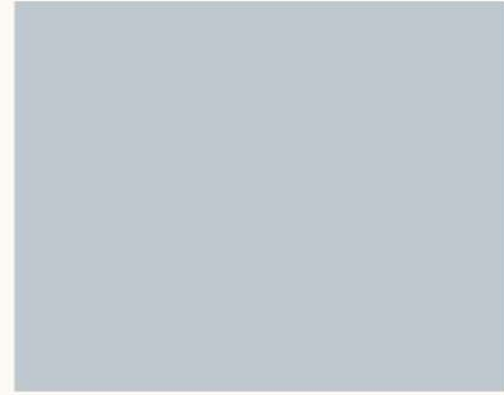

531 - Graublau
Matt



530 - Zartes Rosa
Matt



311 - Magnolie
Matt



574 - Olivgrün Matt



446 - Smaragdgrün
Matt



000 - Jede RAL /
NCS Farbe

Julia

19 mm lackierte MDF-Platte mit einem Rahmenmuster, erhältlich in Supermat-Finish (3 Glanzgrad) oder Matt-Finish (8-12 Glanzgrad). Die linke Seite ist lackiert in der Farbe der rechten Seite, immer mit mattem Finish."





535 - Weiß
Supermat



541 - Kaschmir
Supermat

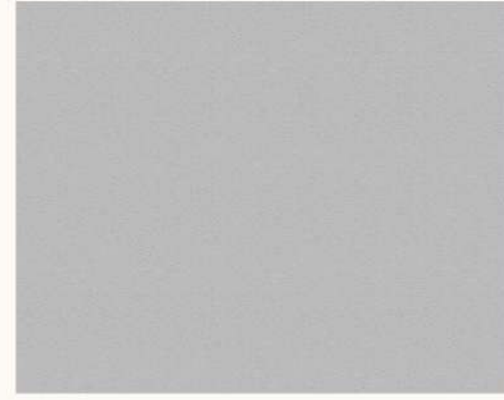

536 - Beige
Supermat



537 - Platingrau
Supermat



538 - Graphit
Supermat



539 - Anthrazit
Supermat

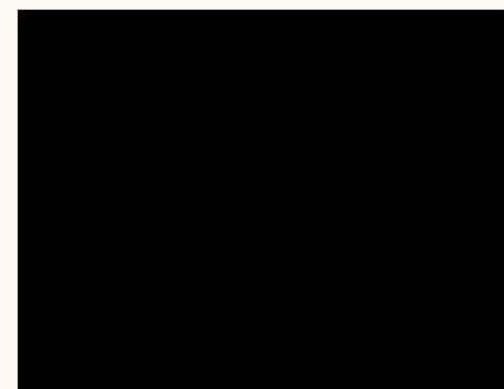

540 - Schwarz
Supermat



000 - Jede RAL /
NCS Farbe

Julia

19 mm lackierte MDF-Platte mit einem Rahmenmuster, erhältlich in Supermat-Finish (3 Glanzgrad) oder Matt-Finish (8-12 Glanzgrad). Die linke Seite ist lackiert in der Farbe der rechten Seite, immer mit mattem Finish."



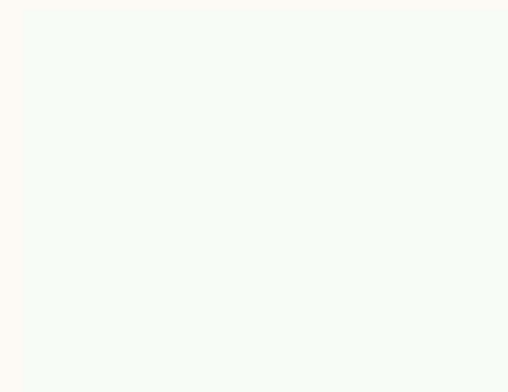

Weiß Matt - 020



Grau Matt - 148

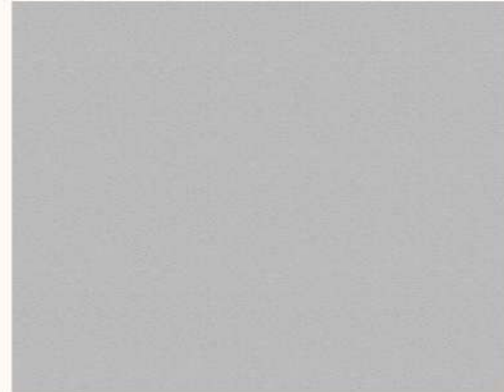

Beige Matt - 450



Platingrau Matt - 525



Antikes Weiß Matt - 349



Basisgrau Matt - 534



182 – grafit mat

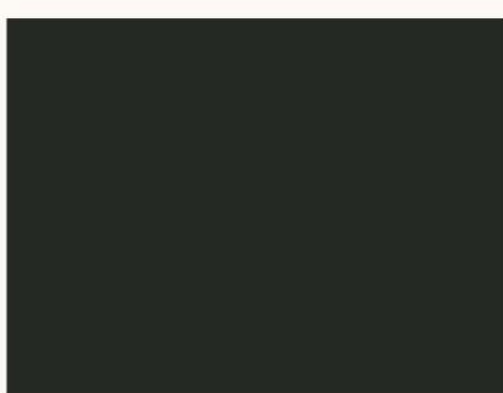

Anthrazit Matt - 442

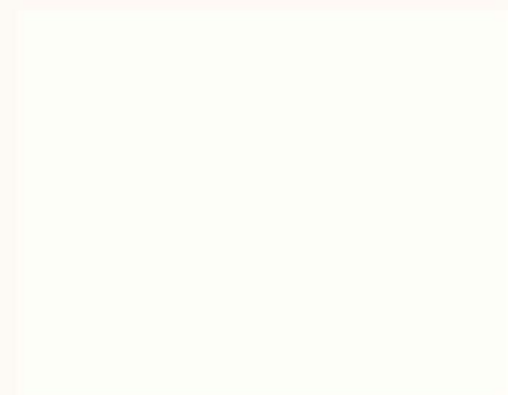

Cremeweiß Matt - 071



Latte Matt - 559



Kaschmir Matt - 444

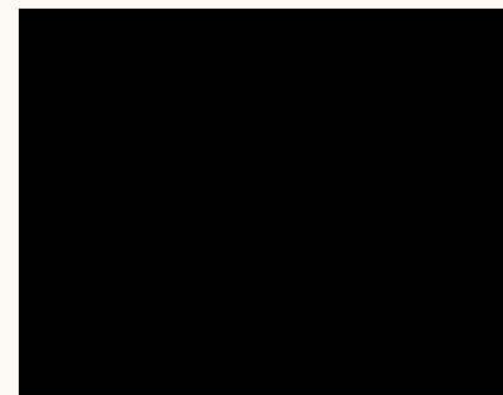

Schwarz Matt - 166

Maria

19 mm lackierte MDF-Platte mit einem Rahmenmuster, erhältlich in Supermat-Finish (3 Glanzgrad), Matt-Finish (8-12 Glanzgrad) oder Hochglanz (>95 Glanzgrad). Die linke Seite ist lackiert in der Farbe der rechten Seite, immer mit mattem Finish.





384 - Steingrau
Matt

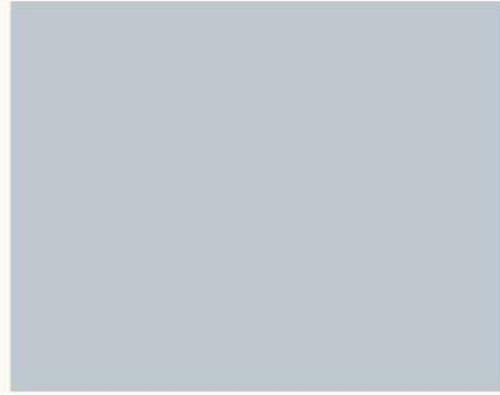

531 - Graublau
Matt



530 - Zartes Rosa
Matt



311 - Magnolie
Matt



574 - Olivgrün Matt



446 - Smaragdgrün
Matt



000 - Jede RAL /
NCS Farbe

Maria

19 mm lackierte MDF-Platte mit einem Rahmenmuster, erhältlich in Supermat-Finish (3 Glanzgrad), Matt-Finish (8-12 Glanzgrad) oder Hochglanz (>95 Glanzgrad). Die linke Seite ist lackiert in der Farbe der rechten Seite, immer mit mattem Finish.



The logo for LEBIOLAND, featuring a stylized 'L' in a square followed by the brand name in a bold, sans-serif font.

Maria

19 mm lackierte MDF-Platte mit einem Rahmenmuster, erhältlich in Supermat-Finish (3 Glanzgrad), Matt-Finish (8-12 Glanzgrad) oder Hochglanz (>95 Glanzgrad). Die linke Seite ist lackiert in der Farbe der rechten Seite, immer mit mattem Finish.

A square color swatch showing a bright, clean white color.

159 - Weiß
Glänzend

A square color swatch showing a light, warm yellowish-beige color.

312 - Magnolia
Glänzend

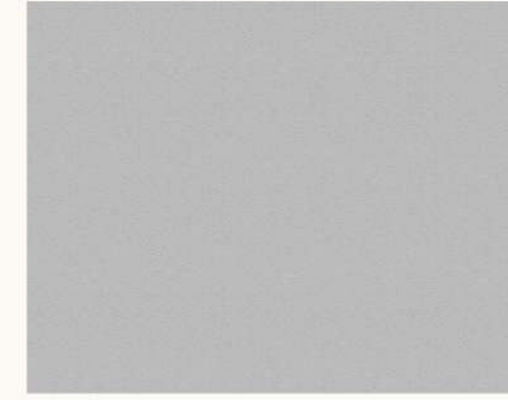
A square color swatch showing a neutral, light grey color.

451 - Beige
Glänzend

A square color swatch showing a dark, rich red color.

000 - Jede RAL /
NCS Farbe

A square color swatch showing a soft, off-white or cream color.

158 - Cremeweiß
Glänzend

A square color swatch showing a muted, earthy green color.

533 - Latte
Glänzend

A square color swatch showing a warm, dusty rose or light pink color.

445 - Kaschmir
Glänzend

A square color swatch showing a dark, charcoal grey color.

385 - Steingrau
Glänzend





535 - Weiß
Supermat



541 - Kaschmir
Supermat

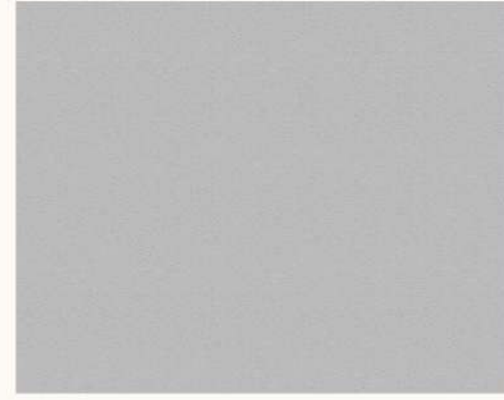

536 - Beige
Supermat



537 - Platingrau
Supermat



538 - Graphit
Supermat

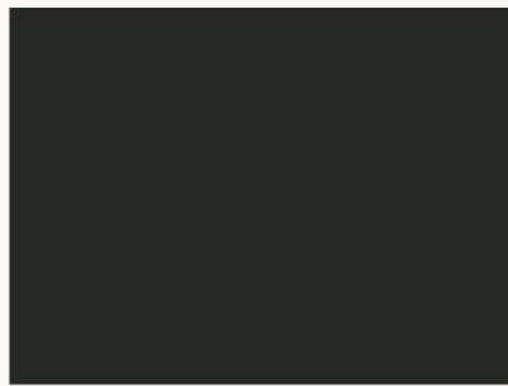

539 - Anthrazit
Supermat

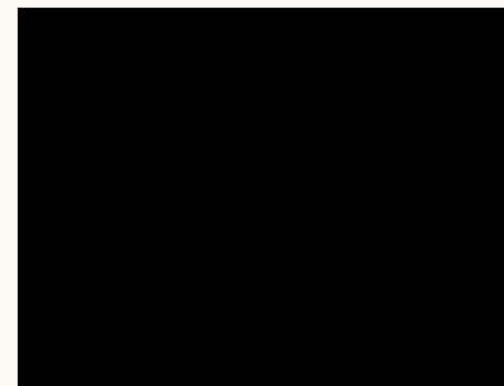

540 - Schwarz
Supermat



000 - Jede RAL /
NCS Farbe

Maria

19 mm lackierte MDF-Platte mit einem Rahmenmuster, erhältlich in Supermat-Finish (3 Glanzgrad), Matt-Finish (8-12 Glanzgrad) oder Hochglanz (>95 Glanzgrad). Die linke Seite ist lackiert in der Farbe der rechten Seite, immer mit mattem Finish.





379 - Natürliche Eiche
im Landhausstil



261 - Graue Eiche

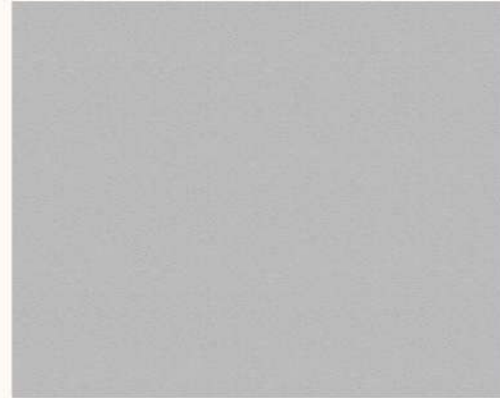

355 - Weiße Eiche

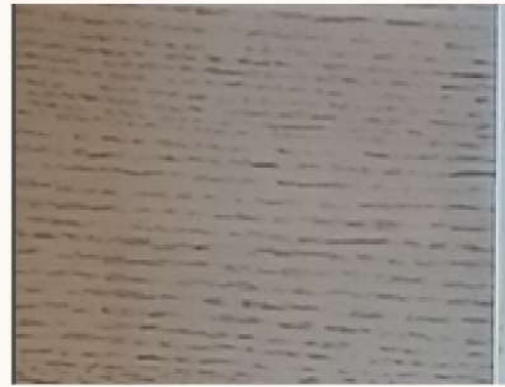

263 - Graue Eiche



551 - Eiche Latte

Marianne

Rahmenförmige Front. Rahmen aus massiver Eiche, MDF-Platte mit Eichenfurnier. Frontstärke 22 mm. Schranktüren mit Sprossen verfügbar





379 - Natürliche Eiche
im Landhausstil



261 - Graue Eiche

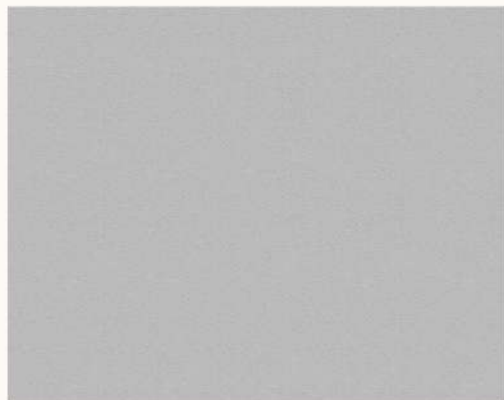

355 - Weiße Eiche



532 - Eiche
dunkelblau

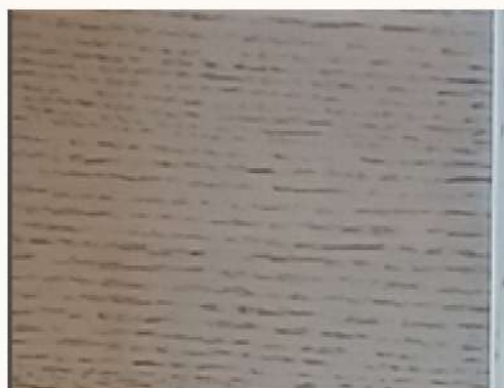

263 – Graue Eiche



Rovere

Front mit Rahmen und Füllung. Massiver Eichenrahmen mit einer Breite von 88 mm und einer Dicke von 22 mm. Das Verbinden der Rahmenteile erfolgt rechtwinklig mit einer Fase von 0,5-1 mm. Die äußere Kante des Rahmens hat eine 2 mm breite Fase oben und unten, während die innere Kante des Rahmens eine Fase von 0,5-1 mm aufweist. Die Füllung besteht aus einer flachen Eichenfurnierplatte mit horizontaler Maserung.



379 –EicheNatur im Landhausstil



261 - Eiche Grau



355 - Weise Eiche



532 - Eiche dunkelblau

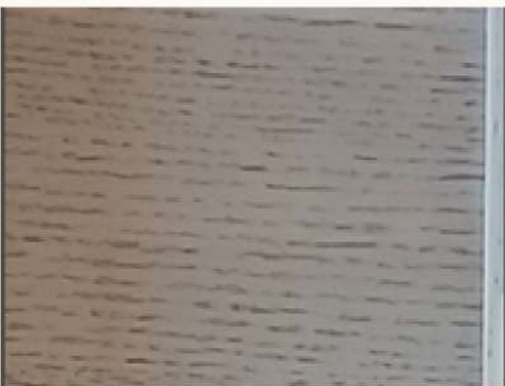

263 – Graue Eiche



Pulito

Rahmenförmige Front ohne Griff.
Massiver Eichenrahmen mit einer Breite von 88 mm und einer Dicke von 22 mm. Die Verbindung der Rahmen erfolgt rechtwinklig mit einer Fase von 0,5-1 mm. Die äußere Kante des Rahmens hat eine 2 mm breite Fase oben und unten, während die Kante des Rahmens eine Fase von 0,5-1 mm aufweist. Die innere Füllung besteht aus einer flachen Eichenfurnierplatte mit horizontaler Maserung. Es gibt eine Griffmulde an der Verbindung zwischen dem horizontalen Rahmen und der Platte.



AL 15 - Rahmen aus Alu, 20 mm dick, 19 mm breit, Schwarz eloxiert mit schwarzer Antisol-Glas



AL 17 - Rahmen aus 20 mm dickem Aluminium, 19 mm breit, Edelstahloptik mit Optiwhite-Glasfüllung.



AL 16 - Rahmen aus 20 mm dickem Alu, 19 mm breit, Schwarz eloxiert mit Stahlgitter



AL 19 - Rahmen aus 20 mm dickem Alu, 45 mm breit, schwarz gebürstet, mit Opti-White-



AL 18 - Rahmen aus 20 mm dickem Alu, 45 mm breit, gebürsteter Stahl, mit Opti-



AL 20 - Rahmen aus 20 mm dickem Alu, vertikal 48 mm breit, schwarz eloxiert, mit Master Vision Sun-Glasfüllung.

Aluminiumfronten

Fronten mit Glas oder Stahlgitter.





550 – Weiß Korpus



362 – Aschgrau U-112



568 - Kaschmir



374 - Steingrau U727

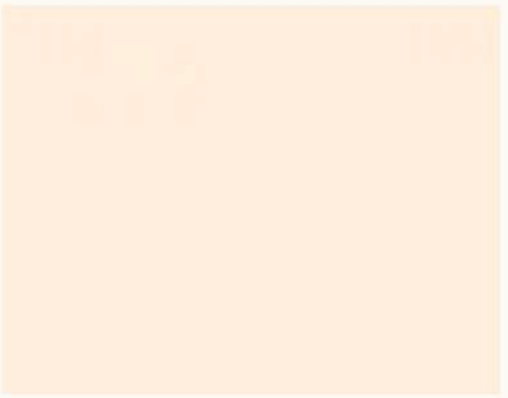

363 - Creme U7035



223 – Graphit U-961



560 - Staubiges Grau



U-190 - Schwarz



561 - Eiche Vicenza



488 - Naturhickory



K003 - Honigeiche



510 - Bronze expressive oak

Korpus

18 mm dicker Spanplatte mit sichtbaren Kanten aus 0,8 mm dickem PVC in Korpusfarbe und 0,5 mm dicker Papierkante an den übrigen Kanten. Rückwände sind aus 3 mm dickem HDF in ähnlicher Farbe wie die Seiten und Regalbretter.

Die Möbel kommen montiert an, außer bei hohen Schränken mit Regalen, die demontiert geliefert werden. Hohe Schränke mit Schubladen und Cargo-Elementen sind bereits montiert. Korpusse und Fronten werden getrennt verpackt und der Monteur setzt die Fronten ein, nachdem er die Korpusse aufgestellt hat.



561 - Eiche Vicenza



488 - Nussbaum natur



K003 - Honigeiche



562 - Nussbaum Lincoln



489 - Eiche Halifax natur



414 - Eiche natur Tabak



441 - Goldene Eiche S129



Dunkler Nussbaum K009



403 - Palisander Flader



Blasser Lancelot-Eichen-R4262



Dunkle Esche K022

Arbeitsplatten

Individuell gefertigte laminatbeschichteten Spanplatte mit verschiedenen Dicken von 38, 25 und 18 mm, versehen mit einem ABS-Kantenband, das farblich an das Laminat angepasst ist. Die Abmessungen entsprechen einem spezifischen Projekt. Es werden Fräsungen für Verbindungen entsprechend dem Projekt vorgenommen. Die linke Seite ist mit einem weißem Gegenlaminat ausgestattet. Es besteht die Möglichkeit, dasselbe Laminat beidseitig als umlaufende Paneele verwendet wird.



482 - torano FC13



483 - albox FC19



481 - montilla FC18



549 - calypso losa



566 - pulpis grey



567 - pulpis dark



564 - terazzo beige



527 - kamień
ventura schwarz

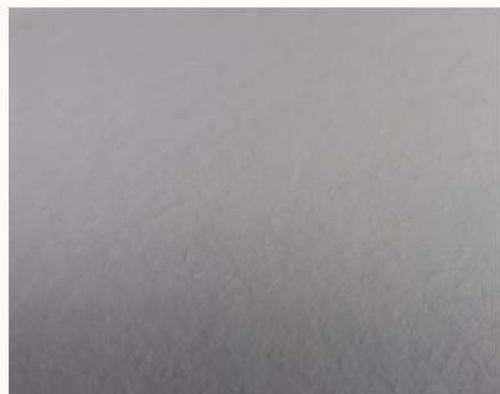

premium white
W1000 ST76



552 - nero losa



548 - schwarzer
Schiefer



523 - chromix
braun

Arbeitsplatten

Spanplatte mit verschiedenen Dicken von 38, 25 und 18 mm, versehen mit einem ABS-Kantenband, das farblich an das Laminat angepasst ist. Die Abmessungen entsprechen einem spezifischen Projekt. Es werden Fräsungen für Verbindungen entsprechend dem Projekt vorgenommen. Die linke Seite ist mit einem weißen Gegenlaminat ausgestattet. Es besteht die Möglichkeit, dasselbe Laminat beidseitig als umlaufende Paneele verwendet wird.



553 – voyage silver urban



547 – voyage copper urban



porfido gesso 3328



mika 3329



beton grau mika 3326



porfido naturale 3324



428 – beton ares FB11



Stein oxid 3421

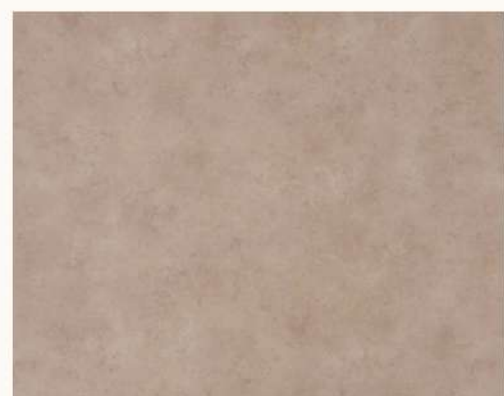

546 – porfido chiaro mika



beton Aschgrau 4298 SU



corten grigio 3331

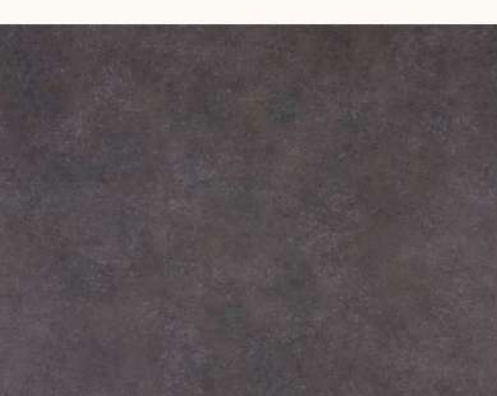

3358 mika brown

Arbeitsplatten

Spanplatte mit verschiedenen Dicken von 38, 25 und 18 mm, versehen mit einem ABS-Kantenband, das farblich an das Laminat angepasst ist. Die Abmessungen entsprechen einem spezifischen Projekt. Es werden Fräsungen für Verbindungen entsprechend dem Projekt vorgenommen. Die linke Seite ist mit einem weißen Gegenlaminat ausgestattet. Es besteht die Möglichkeit, dasselbe Laminat beidseitig als umlaufende Paneele verwendet wird.



528 - iron flow



490: Farblose Eiche mit mikroskopischer Rillenstruktur (AB)



491: Eiche mit weißer mikroskopischer Rillenstruktur (AB)



492: Eiche mit grauer mikroskopischer Rillenstruktur (AB)



493: Eiche mit schwarzer mikroskopischer Rillenstruktur (AB)

Geölte Holzplatten

Eichenarbeitsplatte, der mit einem Ölwachs imprägniert ist, hat eine Dicke von 40 mm und abgerundete Kanten mit einem Radius von 3 mm.



Griffe



U-02/128



PYRAMID/160-ST
PYRAMID/320-ST



RIO/164-ST



US_OVAL



EDGE/20-ST
EDGE/160-ST
EDGE/600-ST



UF-2/160
UF-2/448



U-51/ST



U-55/320/S



U-69/160/S



U-NELA SZCZOTKA



U-SOFT_V2



U-77/ST/320



U-76/ST/160



U-78/ST



U_VICA 177



LK 014/IX

LK 013/IX

LKP 009/IX

LKP 010/IX



U-36/160/C



PYRAMID/160-CZ
PYRAMID/320-CZ



U-43/160/C



US_OVAL-CZ

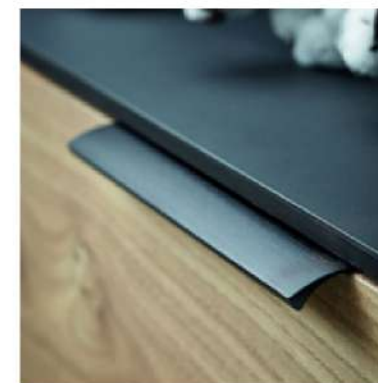

EDGE/20-CZ
EDGE/160-CZ
EDGE/600-CZ

Griffe



U-44/C



U-52/C



U-54/320/C



U-68/160/C



U-NELA SCHWARZ



U-64/160/C



U-71/C/320



U-70/C/160



U-72/C



U_VICA 177/CZ



LK 014/C

LK 013/C



LKP 009/C



LKP 010/C

Griffe



U-60/160/CS



U-61/160/CS



U-66/160/C



U-67/192/C



U-38/CK



U-39/160/CK



UDGV-01



UD-03/128



UD-02/96



UD-01/64



U-53/160/Z



U-65/160/Z



U-34/160/Z



EDGE/20-Z
EDGE/160-Z



LK 014/Z
LK 013/Z



LKP 009/Z
LKP 010/Z

Griffe



U-35/160/M



U-40/160/M



U-41/160/M



U-42/M



EDGE/160-M



EDGE/20-M



LK 014/B
LK 014/BI



LK 013/B
LK 013/BI



LKP 009/B
LKP 009/BI



LKP 010/B
LKP 010/BI



EDGE/160-BR

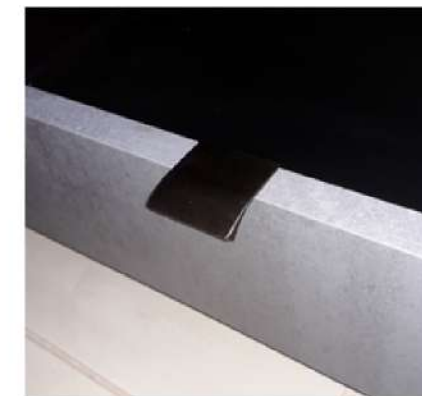

EDGE/20-BR



LK 014



LK 013



LKP 009



LKP 010



TIP-ON STANDARD



M Anthrazit



MR Anthrazit



MS Anthrazit



MB Anthrazit



M Grau



MR Grau



MS Grau



MB Grau



M Weiß



MR Weiß



MS Weiß



MB Weiß

"Schubladen

Merivobox: eine gemeinsame Plattform - 3 verschiedene Schubladen - mit Reling, mit Glas und mit metallischem Boxcap, in 3 Farben - passend zum Cargo, matte Oberfläche, minimalistisches Design, rechtwinklige Seiten: optimale Raumausnutzung, synchronisiertes Schienensystem, Belastbarkeit von 40 und 70 kg, geschmeidige, geräuschlose und leichte Bewegung, vollständiger Auszug.



tip-on blumotion



servo drive



Arena Classic Weiß



Arena Classic Grau



Arena Classic Silber



Arena Style
Anthrazit

Cargo



Libelle Anthrazit



Le Mans



Magic Corner
Comfort



Halbkreis



Dreiviertelkreis



Dreiviertelkreis



PEKA



PEKA



PEKA



PEKA



PEKA



PEKA

Beschläge und Zubehör



BLUM blumotion



Aventos HK



Free Flap



Aventos HF



Free Slide i
Aventos HL



Ambia Line



Antirutschmatten für
Schubladen.



Einsätze aus
Kunststoff



Einsätze aus Holz



Leistenbeleuchtung



Spotbeleuchtung



Vitrinenbeleuchtung



Schrankbeleuchtung

Beleuchtung und Sortierer



KOSZ2



KOSZ4



KOSZ5



KOSZ6



DZ-6/SELECT



DZ-6/OEKO



DZ-6 /PULLBOY_Z



KOSZ1



SERVO UNO





Rollladenschränke

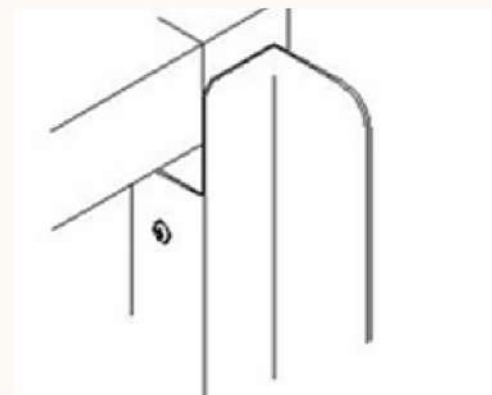

Schutz am
Backofen

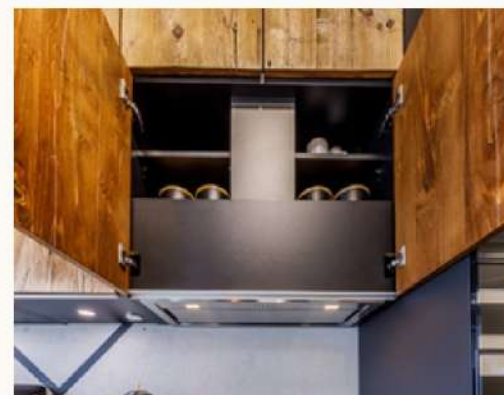

Hauben im Schrank



Sockel für Paneele

Sonstiges



Legrabox Pure



Lackierte Seiten



Frame-Regale



Tischbeine



Möbel für das
Wohnzimmer



Home office

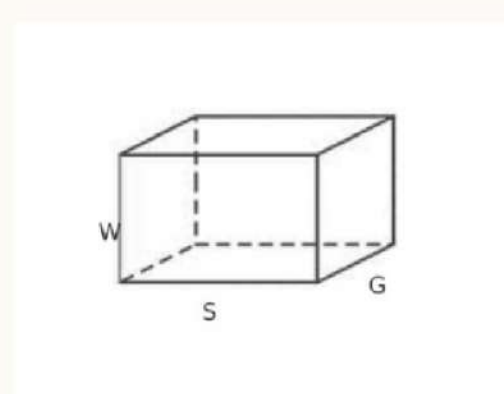

Maßanfertigungen und
Konstruktionen



Reinigungs- und
Pflegemittel



Typenreihe

3000 verschiedene Arten von Schränken 1
Höhe Unterschrank: 720 1 Höhe Unterschrank
niedrig: 360 1 Höhe Mittelschrank: 1290
Einbau bis zur Decke
2 Höhe Hochschränke: 2006, 2153 9 Höhe
Hängeschränke: 360-1295 2 Höhe Aufsätze:
355, 428 2 Raster für Unterschränke 140 x 5
176 x 4 Griffloser Typ: Höhe Unterschrank: 720
Raster Front 161 x 4 = 686 Korpus Tiefe 560
unten 330 hängend Verfügbarer unterer
Korpus 330 und hängender 560

Typenreihe

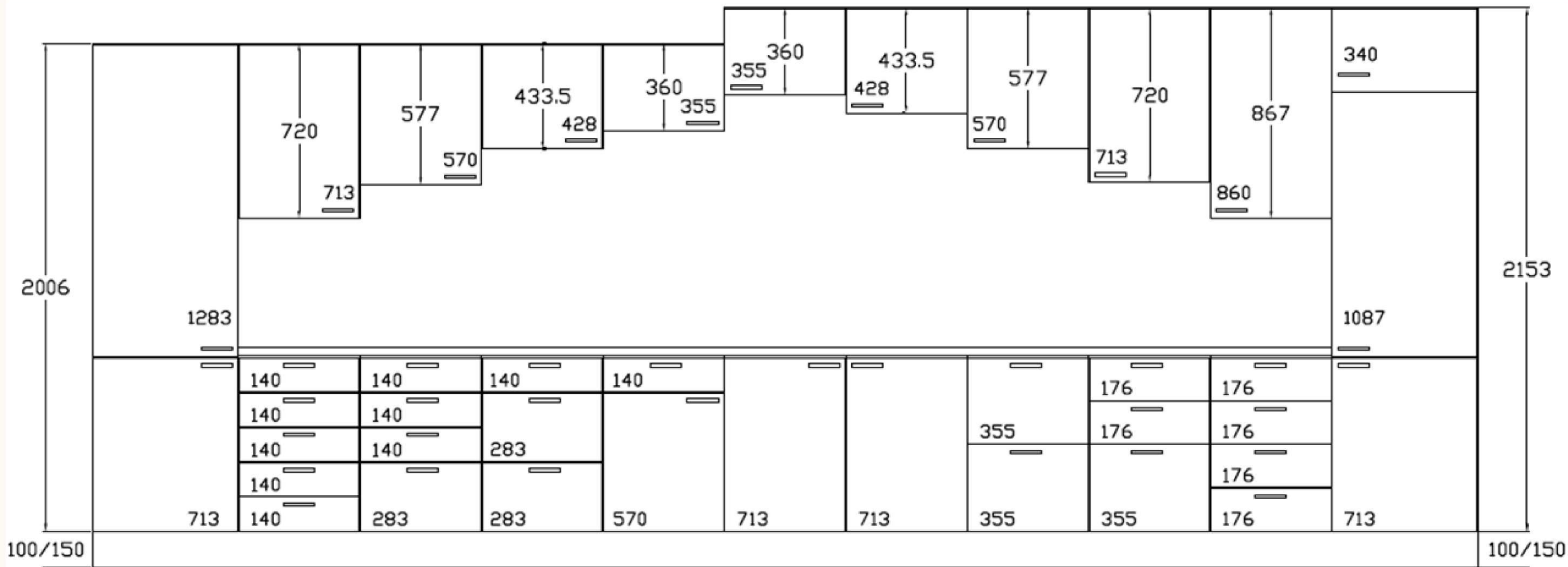

Podział szuflad na 5

Podział szuflad na 4

Typenreihe

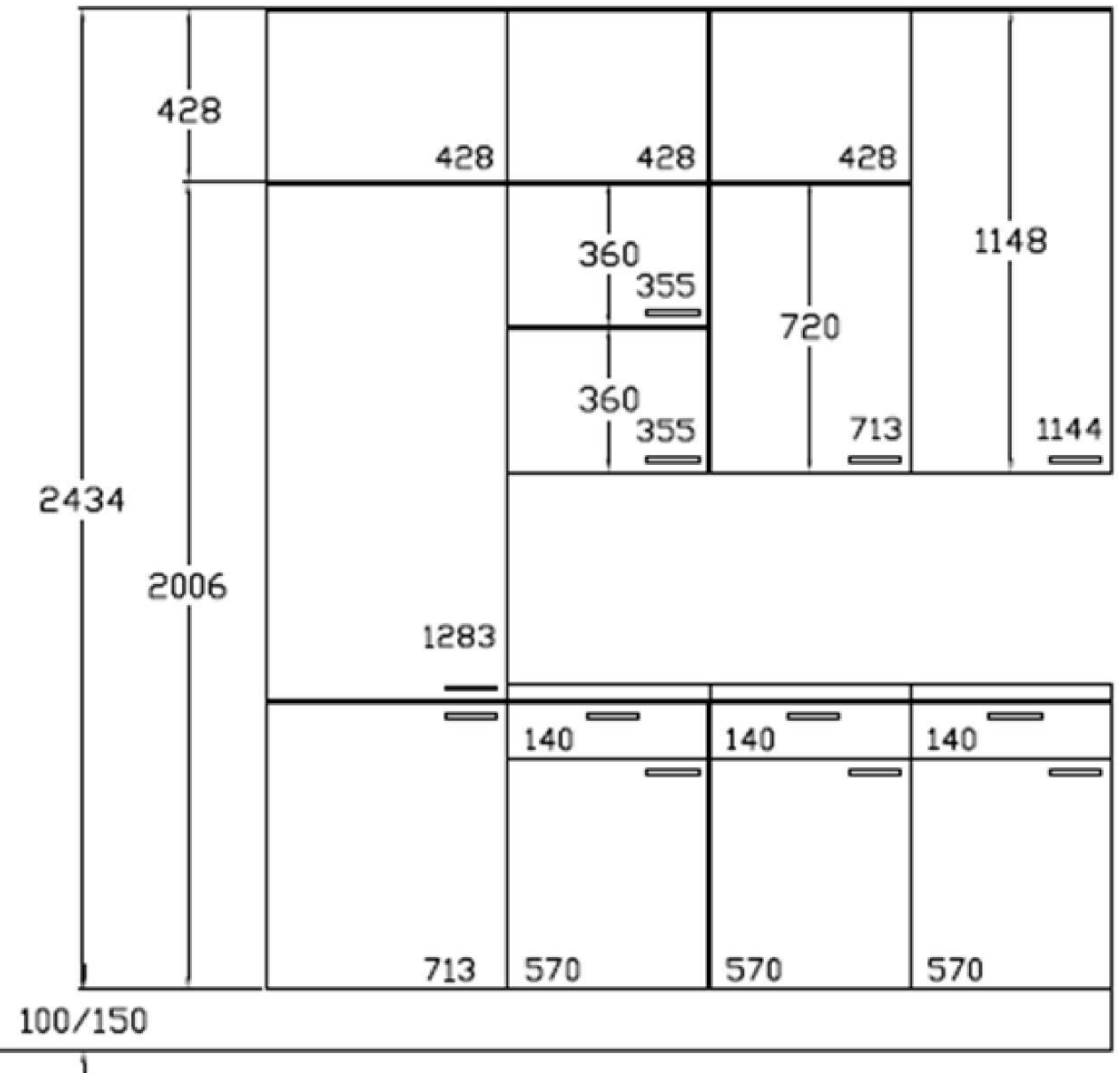
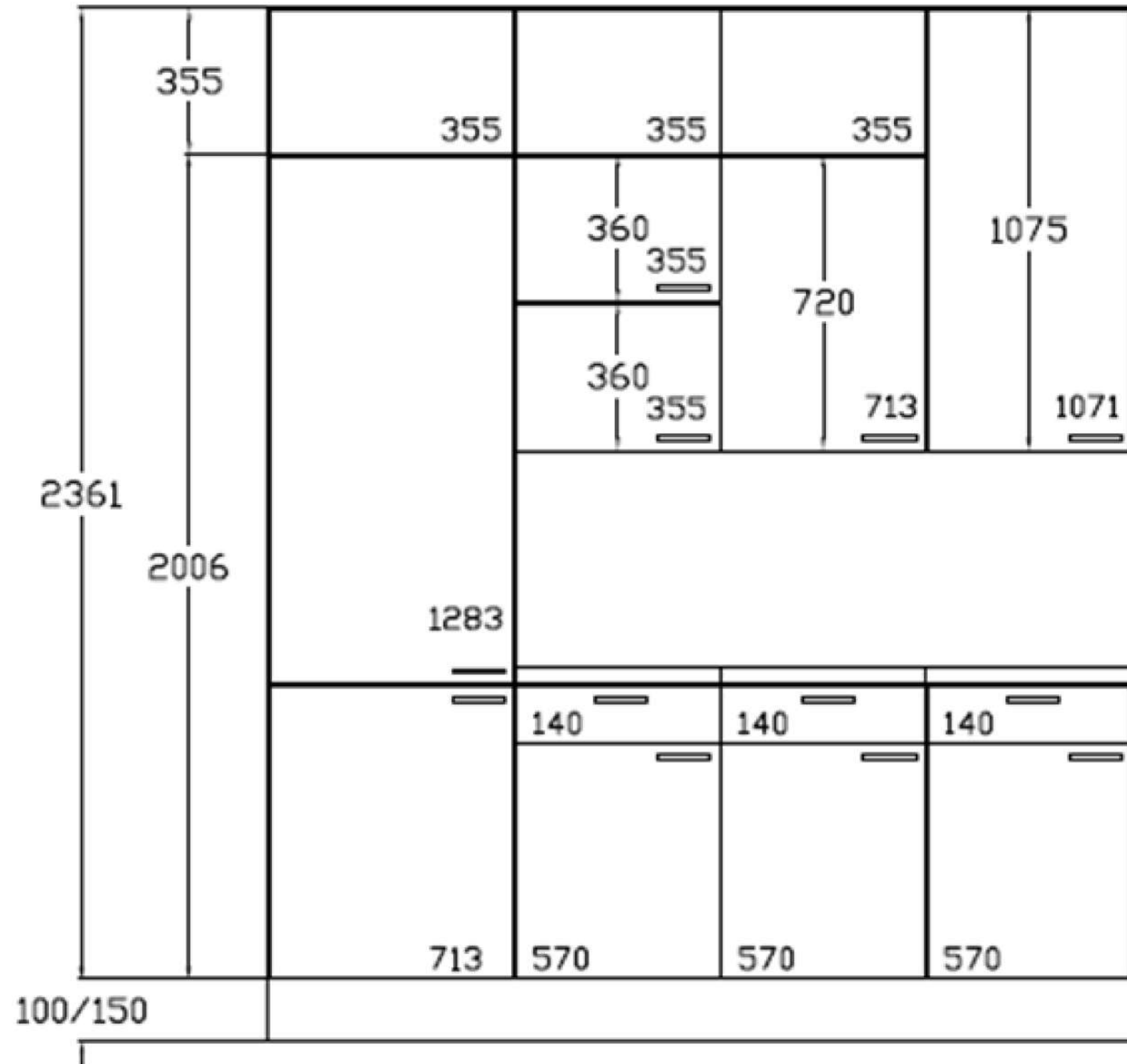

Typenreihe

Nadstawki h-355

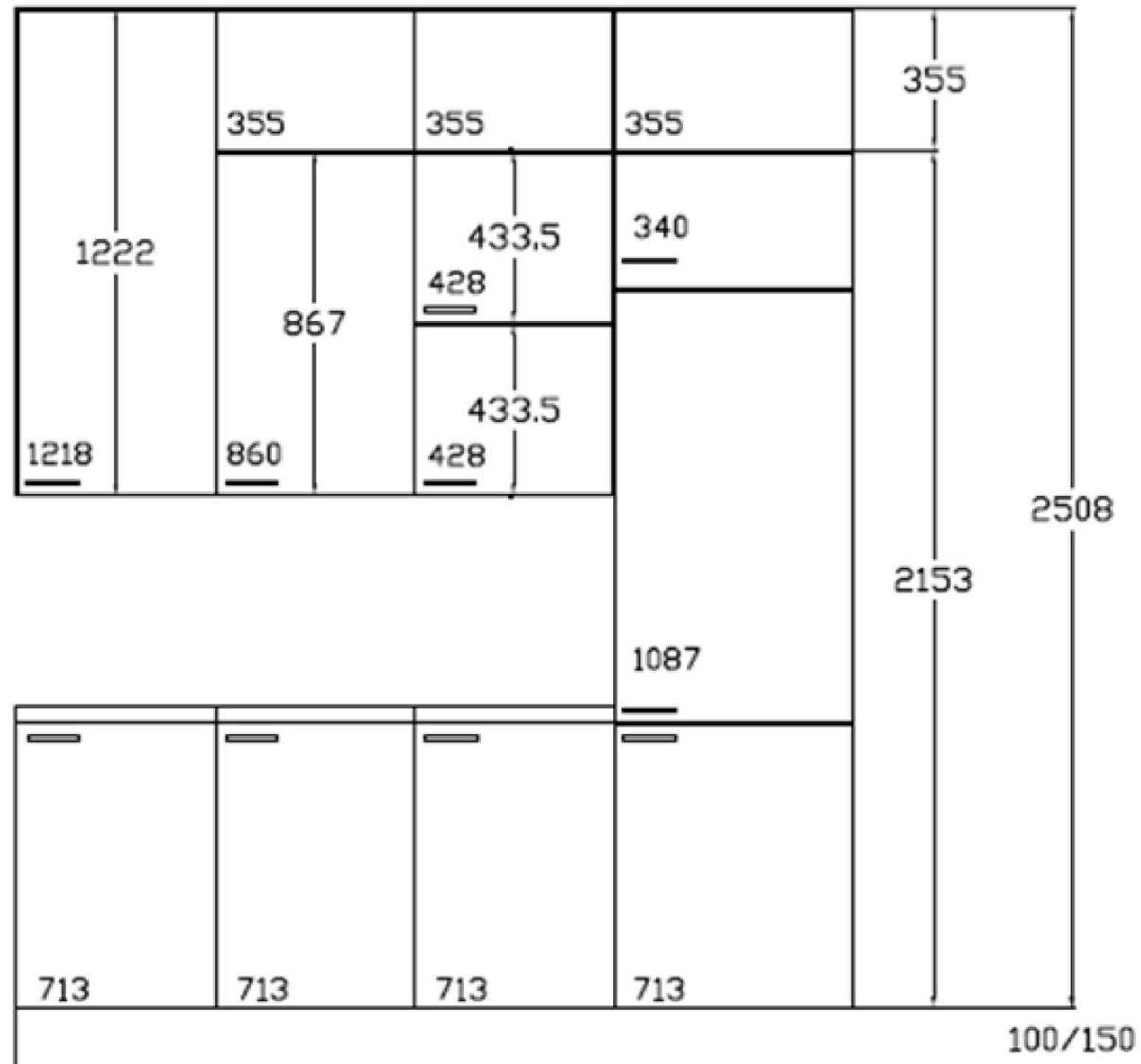

Nadstawki h-428

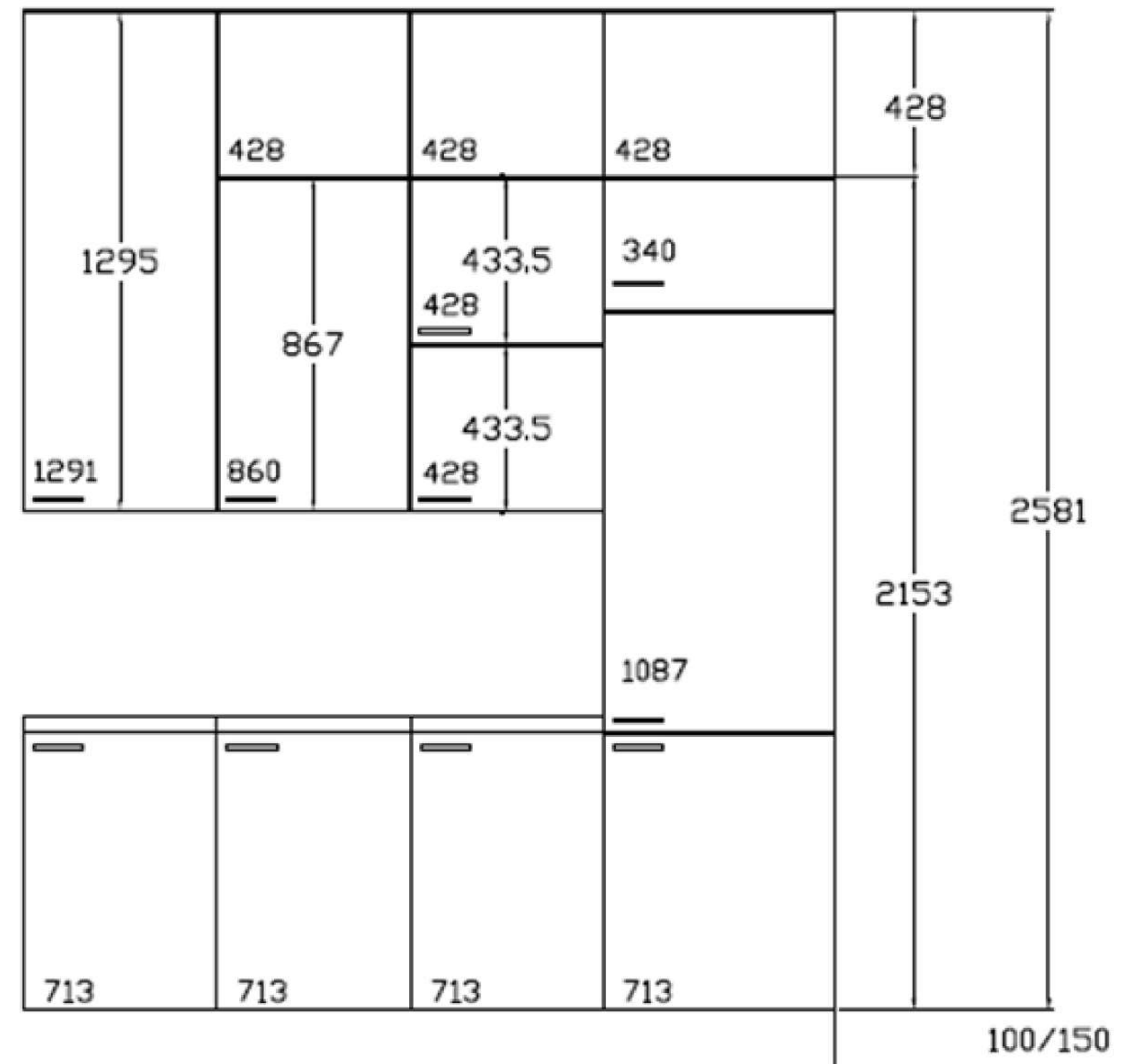

Grifflose Typenreihe

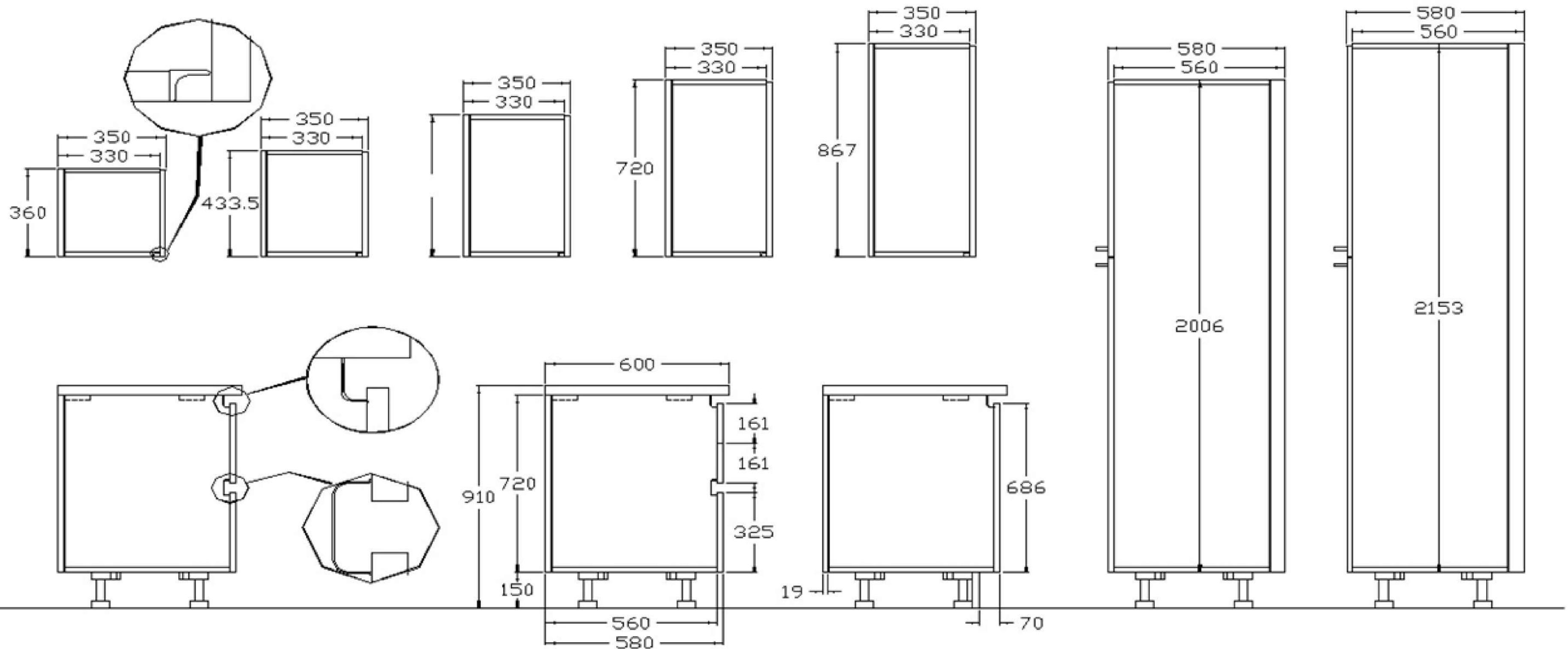

Grifflose Typenreihe

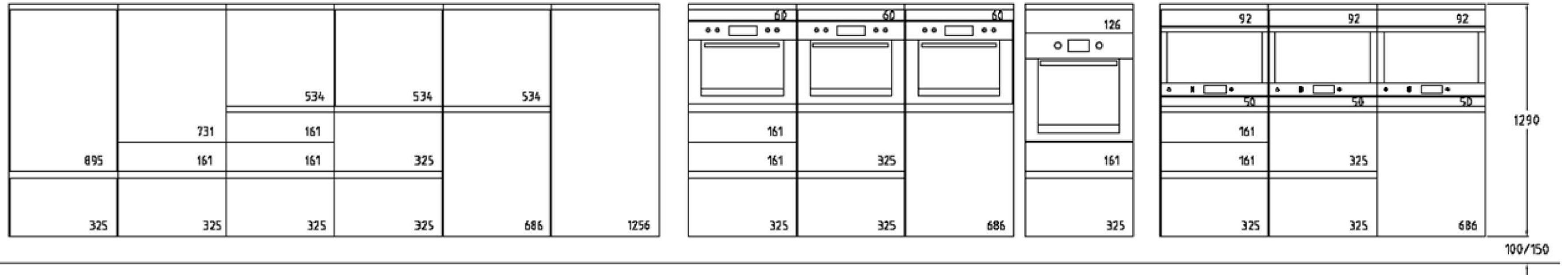
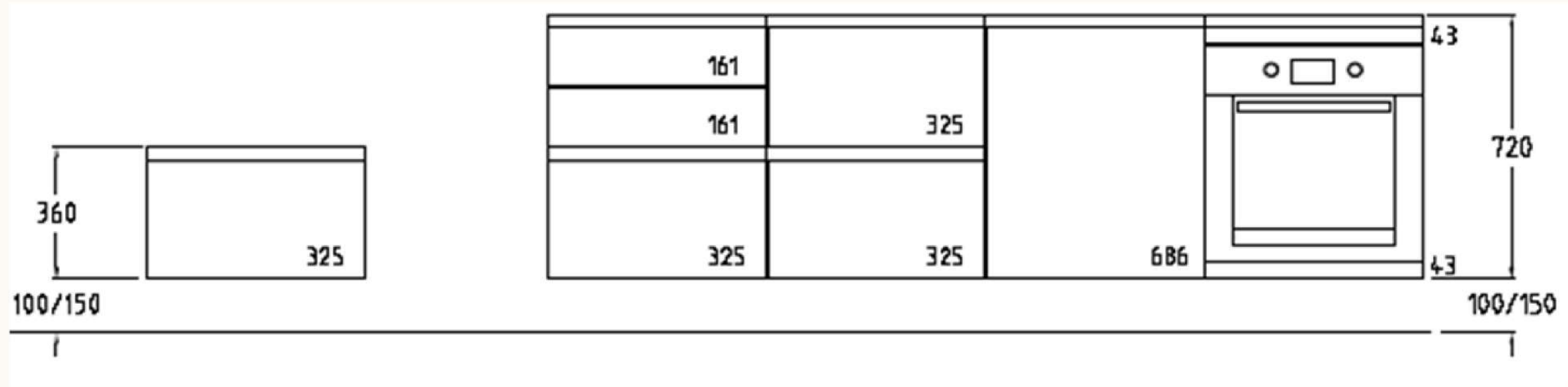

Grifflose Typenreihe

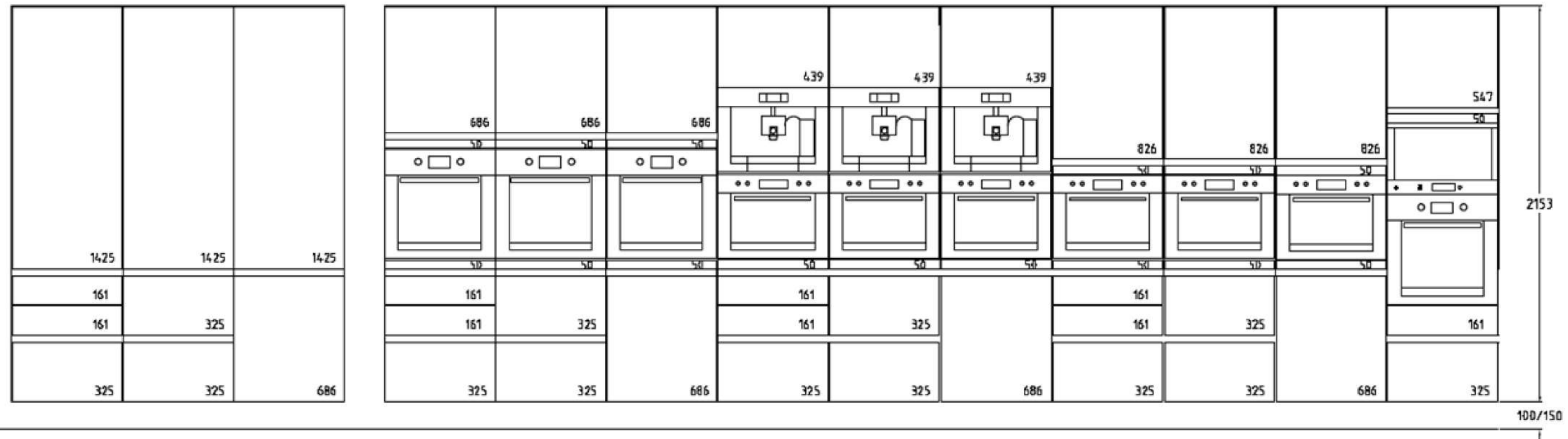
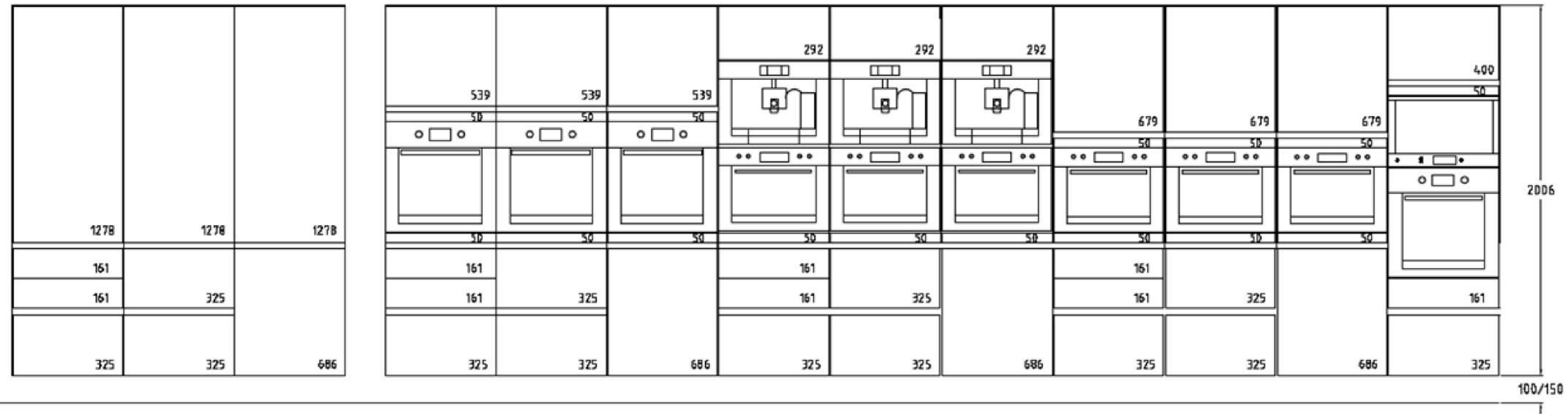

Die Lacke basieren auf Acrylharzen und sind speziell für Küchenmöbel bestimmt. Sie zeichnen sich durch erhöhte Beständigkeit gegen Abrieb, chemische Einflüsse und Feuchtigkeit aus. Jedoch hat die UV-Strahlung, die zu einer Alterung der Beschichtung führt, einen großen Einfluss auf das endgültige Finish. Es ist zu erwarten, dass bei Elementen, die in einer anderen Produktionsreihe bestellt wurden, ein anderer Farbton des Finishs auftreten kann. Aus diesem Grund und aufgrund der geringen Größe der Farbmuster im Musterbuch können sich Elemente und Fronten einer gesamten Küche hinsichtlich der Lackfarbe unterscheiden. Bei der Bestellung von Elementen für ein bestehendes Set ist es daher notwendig, ein Farbmuster bereitzustellen.

Furnier, auch als Naturholzfurnier bezeichnet, ist Holz, das dünn in Scheiben von 0,6 bis 2 mm Dicke geschnitten wird. Durch das Aufkleben von Furnier auf eine Holzfaserverplatte erhält man ein ähnliches Aussehen wie bei massivem Holz und reduziert gleichzeitig die Unvollkommenheiten des Holzes aufgrund seiner Anfälligkeit für Luftfeuchtigkeit. Ähnlich wie bei Holz weist Furnier die Merkmale von individuellen Mustern und Schattierungen, Unregelmäßigkeiten in der Struktur, Farbkontraste, Verfärbungen und Astlöcher auf. Diese Eigenschaften des Naturfurniers, charakteristisch für Materialien natürlichen Ursprungs, die aus unterschiedlichen Umweltbedingungen resultieren, unterscheiden es von künstlich hergestellten Materialien wie Laminat und sind daher keine Fehler des Produkts. Im Gegenteil, sie sind ein Zeichen von guter Qualität und ermöglichen eine Personalisierung des Innenraums. Die auf den Farbmusterkarten dargestellten Holzfarben und -muster können auf den Fronten eines gesamten Möbelsets aufgrund der genannten Furniereigenschaften und der begrenzten Oberfläche im Farbmusterbuch nicht wiederholt werden. Es sollte vermieden werden, Fronten nach einer bestimmten Nutzungsdauer der Küche nachzubestellen, da die UV-Strahlung eine Farbänderung bewirkt.

Platte, ähnlich wie Furnier, ist jedoch ein dickeres Material als Furnier, mit einer Dicke von 2 mm und mehr. Es weist die gleichen Merkmale wie Furnier auf.

Die Eigenschaften von Holz sind Unregelmäßigkeiten in der Struktur, unterschiedliche Strukturen, Farbkontraste, Verfärbungen und Astlöcher. Diese morphologischen Eigenschaften von Holz, charakteristisch für Materialien natürlichen Ursprungs, die aus unterschiedlichen Umweltbedingungen resultieren, unterscheiden Holz von künstlich hergestellten Materialien und sind daher keine Fehler des Produkts. Im Gegenteil, sie sind ein Zeichen von guter Qualität. Die auf den Farbmusterkarten dargestellten Holzfarben und -muster können auf den Fronten eines gesamten Möbelsets aufgrund der genannten Holzeigenschaften und der begrenzten Oberfläche im Farbmusterbuch nicht wiederholt werden. Es sollte vermieden werden, Fronten nach einer bestimmten Nutzungsdauer der Küche nachzubestellen, da die UV-Strahlung eine Farbänderung bewirkt.

Massivholz ist ein Material, das besonders empfindlich auf Luftfeuchtigkeit reagiert. Wir sagen, dass Holz arbeitet. Obwohl das Versiegeln der Holzoberfläche diese Eigenschaft verlangsamen kann, kann man sie nicht vollständig ausschließen. Daher sollte darauf geachtet werden, dass die Luftfeuchtigkeit in der Küche zwischen 40 und 70 % liegt. Kurzzeitige Überschreitungen von 2-3 Tagen haben keinen negativen Einfluss. Auch Sie als Benutzer der Küche werden sich in dieser Luftfeuchtigkeit am wohlsten fühlen.

Altholz hat einen deutlich sichtbaren authentischen Charakter und seine Unvollkommenheiten als charakteristische Elemente dieses Designs. Auffällige Holzzeichnungen, Astlöcher, Farbkontraste, Verfärbungen, feine Risse. Herausfallende Astlöcher sind leicht mit Wachsen gefüllt, aber nicht völlig glatt. Zeichen von Gebrauchsspuren (used look), jedoch ohne Absplitterungen an den Kanten. Aufgrund des natürlichen Charakters des Produkts können unterschiedliche Farbtöne aus verschiedenen Produktionschargen sowie Unterschiede zwischen dem gekauften Produkt und der begrenzten Musterfläche auftreten. Die Verwendung von Birkenfurnier und Altholz für die Fronten wirkt sich auf ihre physikalischen Eigenschaften aus, insbesondere auf ihre Biegung. Es ist zu erwarten, dass aufgrund der verwendeten Materialart für Fronten der maximale Biegepfahl 3 mm pro 1 m Frontlänge beträgt.